

Neptune Henley Kitchen Instructions & Design Guide



Welcome

Welcome to your Neptune Henley Kitchen Instructions & Design Guide.

Please read through the whole fitting guide thoroughly prior to fitting. This guide is designed to help you plan and fit your Neptune Kitchen easily and accurately.

Henley Cabinets are often very heavy. For your own Safety please do not attempt to lift them by yourself.

Tools needed

• Long Spirit levels • Tape measure • Mitre saw • General hand tools • Wood adhesive • Pin gun

Contents

Section	Page	Section	Page
1 Henley Kitchen Concept	2	9 Skirting	12
2 Cabinet Installation	2	10 Lighting	12
3 Levelling	6	11 Larders	12
4 Offsetting	7	12 Drawer Removal & Adjustment	13
5 Attachment	7	13 Appliances	14
6 Feet Design	8	14 Handles	15
7 Feet Fitting	10	15 Care & Maintenance	16
8 Mouldings	11	16 Contact Information	16

1. Henley Kitchen Concept

The Neptune Henley kitchen is designed to combine the benefits of a modular kitchen with the look and feel of an individually sized and crafted bespoke kitchen. The concept allows individual cabinets to be precisely levelled and joined giving a straightforward installation. The moulding and cornice detailing allows a seamless built-in look to be achieved. This is key to the Henley design concept.

2. Cabinet Installation

Base Cabinets

1. Before you begin the floor surface should be fully finished. This is the most reliable way of achieving a good fit.
2. Level cabinets & set height to 890mm from the floor at the lowest point in the room. (see *Levelling*, page 6)
3. The front face of the cabinet should be 600mm from the wall in most installations. (There is a void behind cabinets to allow for services and 560 -600mm fitting.) This distance may change depending on pipework or the worktop depth that will be fitted. A good method of doing this is to mark a line where the front face of the cabinets should be, and then working to that Datum.

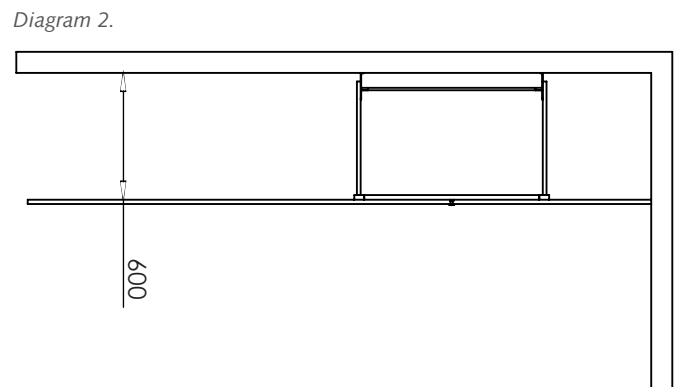
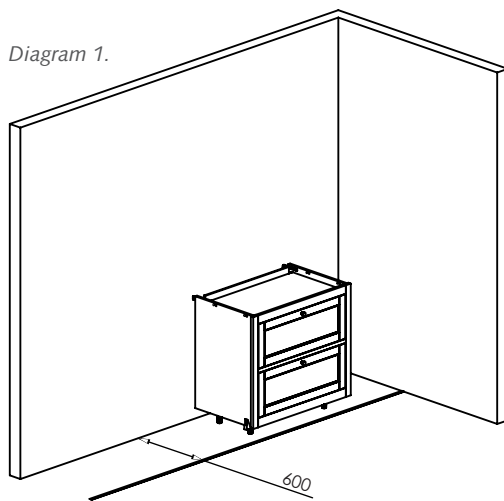

4. Decide on whether any cabinets will be offset. (see *Offsetting*, page 7)
5. Join neighbouring cabinets together using the supplied fittings. (see *Attachment*, page 7)
6. Attach cabinets to wall using the supplied brackets and suitable wall fixings.

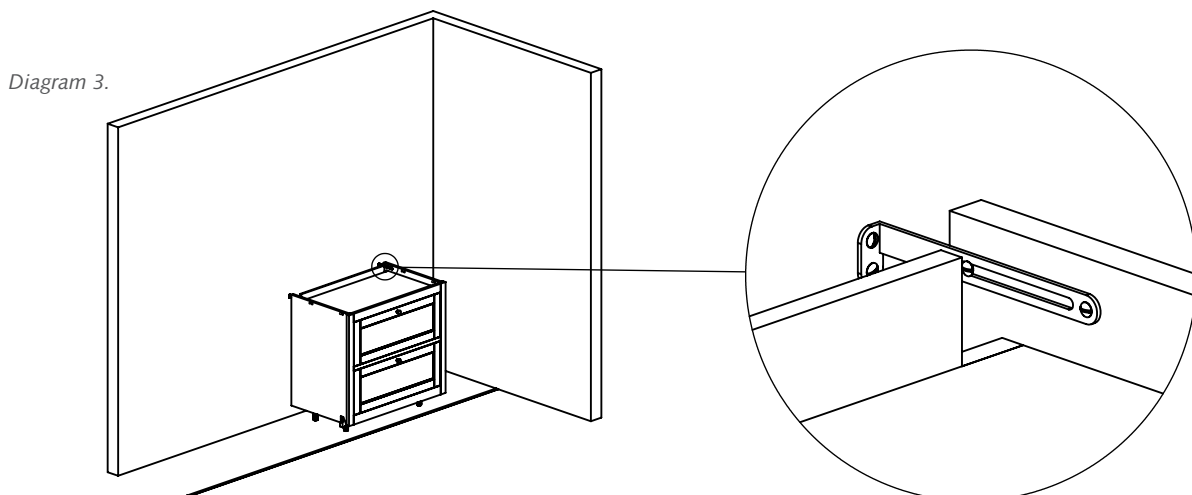

7. Attach end panels to any cabinets that require them. (see *End Panels, page 5*)
8. Decide on feet layout. (see *Feet Design, page 8*)
9. Cut Kick Board to length and screw to the cabinets at regular intervals. For un-even floors it may be necessary to scribe the kick board. (see *Feet Fitting, page 10*)

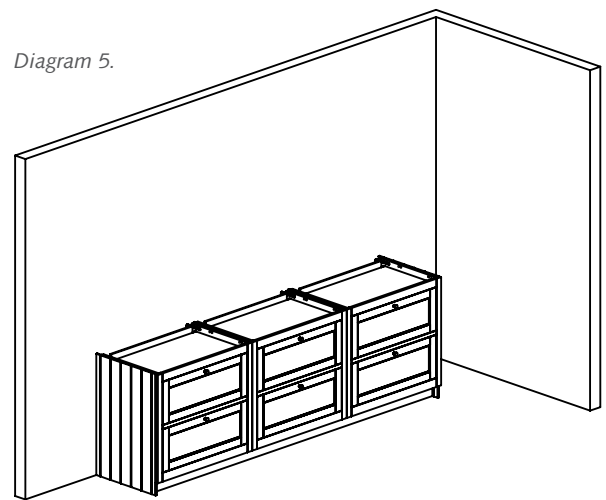
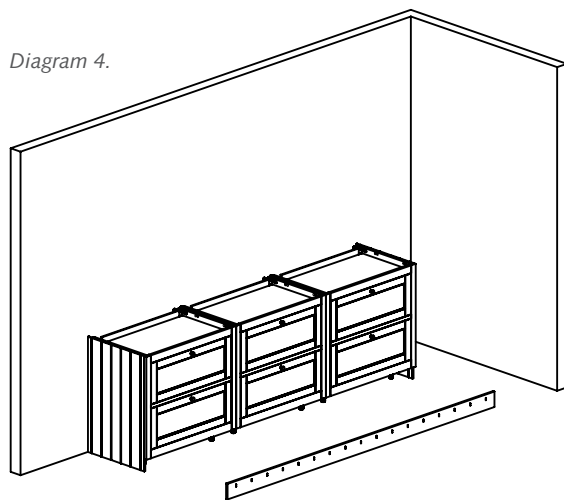

10. Attach feet blocks in correct locations to the Plinth. (see *Feet Fitting, page 10*)
11. Attach the feet to the foot blocks (see *Feet Fitting, page 10*).

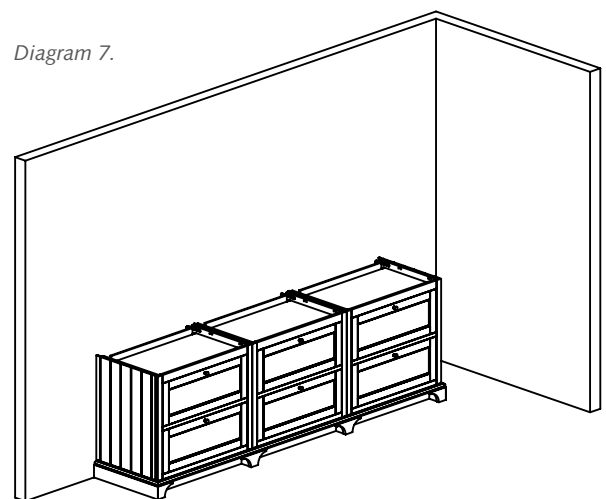
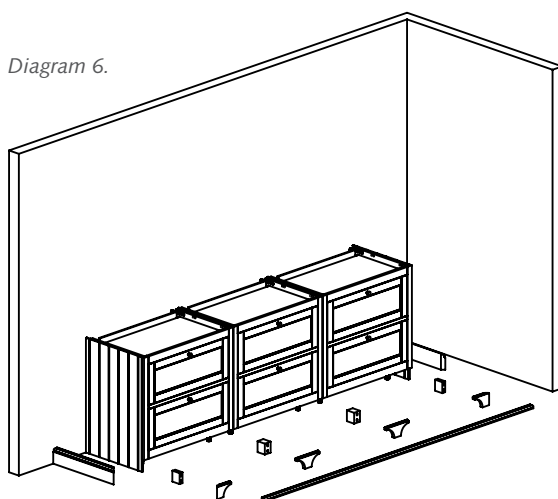

12. Cut and fit any skirting board that is required. (see *Skirting, page 12*)
13. Cut lower moulding to size and attach to feet and cabinet. (see *Mouldings, page 11*)
14. Cut mid-moulding to size. This can be attached before or after the worktop has been fitted.(see *Mouldings, page 11*)
15. We recomend a worktop overhang of 30mm or more from the front of the cabinet so that the mid-moulding can be shown off!

Wall Cabinets

1. Wall cabinets are designed to be screwed directly to the wall using a suitable fixing for your type of wall. To position the cabinets on the wall a baton should first be fitted to the wall, 2055mm from the floor for the cabinets to hang on. The final height of the wall cabinets without cornice should be 2155mm if you would like the cornice height to match full height cabinets.

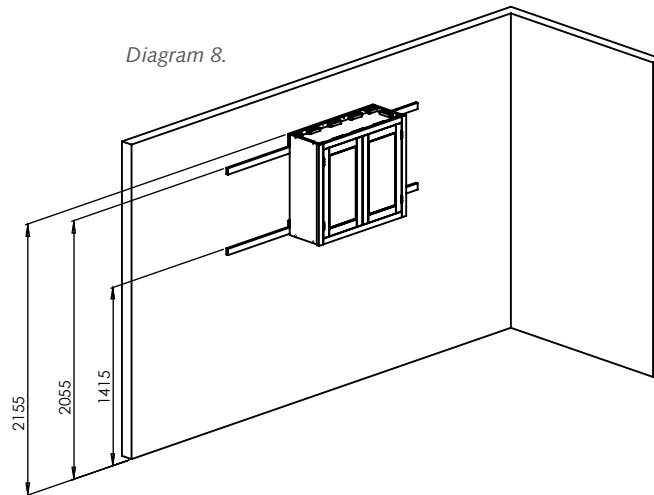

2. A second baton 1415mm from the floor may be used with or instead of the top baton. This is to allow greater fitting flexibility.
3. Individually hang each cabinet on the baton.
4. Attach the cabinet to the wall by screwing the back panel through the top and bottom recess.
5. Attach neighbouring cabinets to each other using suitable woodscrews through the side panel at the top and bottom recess.

Full Height Cabinets

1. Position, level and attach in the same way as base cabinets.
2. The front face of the cabinet can be placed 600-700mm from the wall depending on your worktop and kitchen design.

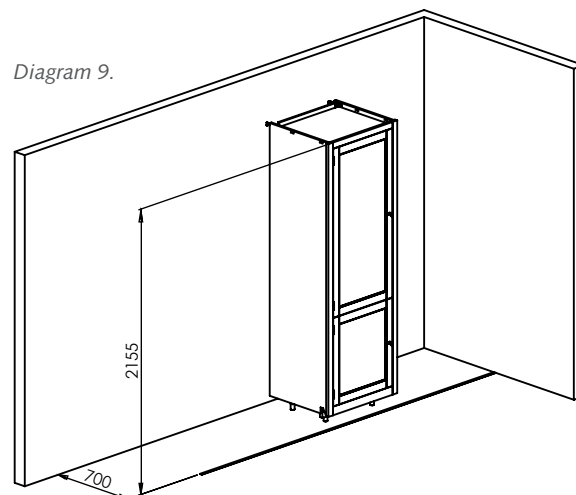

3. The cornice should be attached to the cabinets in the same way as for wall cabinets.

End Panels

End panels should be attached to cabinets at the end of a run where the carcass can be seen. They should be attached with wood glue or grab adhesive.

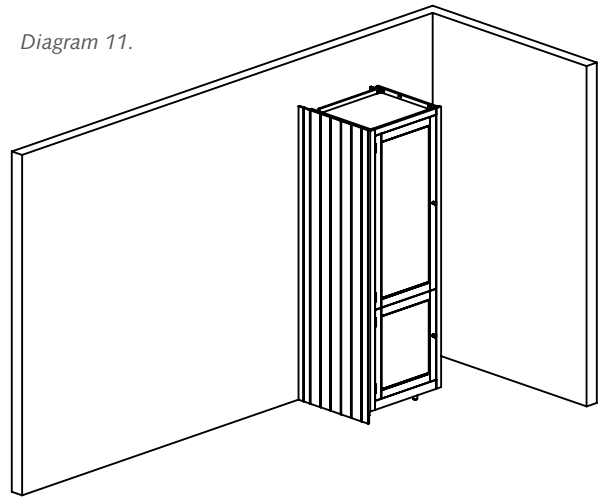
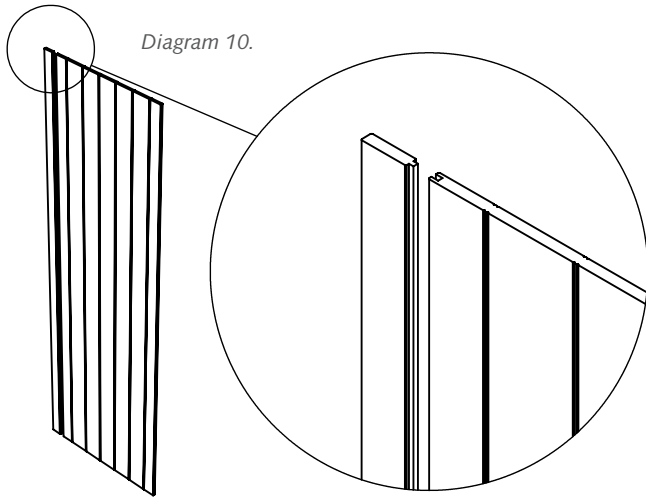

End panels are supplied with a solid oak scribing strip. These are to be used in addition to the end panel where extra depth of end panel is required or to cater for uneven walls. In such scenarios the scribing strip should be scribed to suit the wall and then glued to the end panel.

Cornice

1. Cornice should be fitted to all wall cabinets and full height cabinets.
2. Sections should be joined using an equal mitre joint.
3. The cornice can be glued or screwed to the cabinet. The cabinet must be pre-drilled before screwing the cornice, to prevent the carcass wood splitting.
4. The cornice mitre joints should be fixed with wood glue. Care should be taken to remove any excess adhesive.

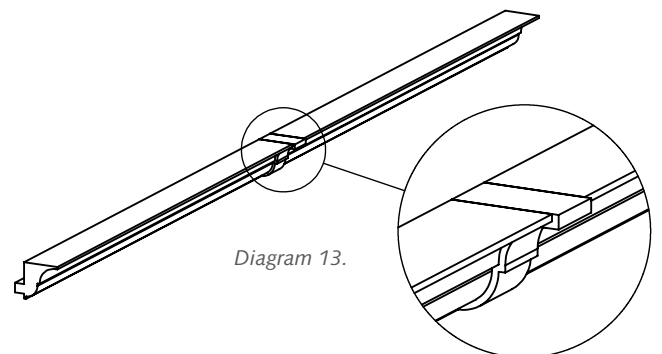
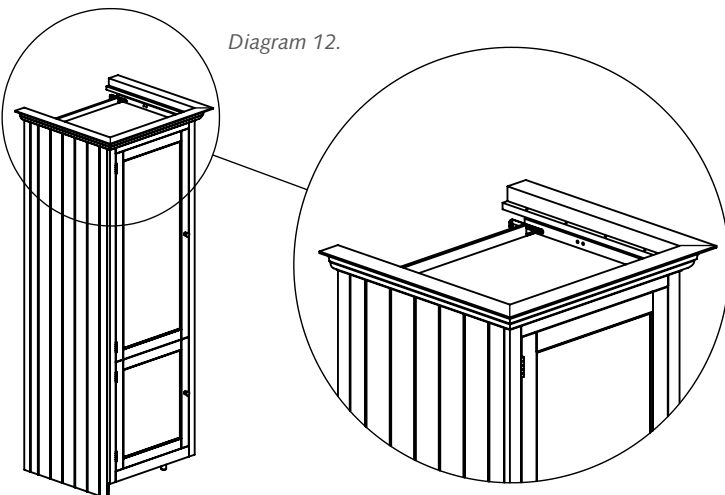

5. To join multiple lengths of cornice for a long run an optional Cornice Jointing Block can be used. This allows the joint between two pieces of cornice to be disguised. (see *diagram 13*)

3. Levelling

It is very important to ensure that all cabinets are level and true. Time spent levelling is critical to a successful kitchen fit.

All base cabinets are supplied with height adjustable feet that can be used in two ways;

1. Using the supplied Allen key the adjustable feet can be turned from within the cabinet. (Drawers & hardware may need to be removed for some cabinets, see section 10 for drawer removal) Turning the Allen Key socket clockwise will extend the foot.
2. The feet can also be adjusted directly by hand from the exterior of the cabinet. This is easiest if the cabinet is on its side or back.

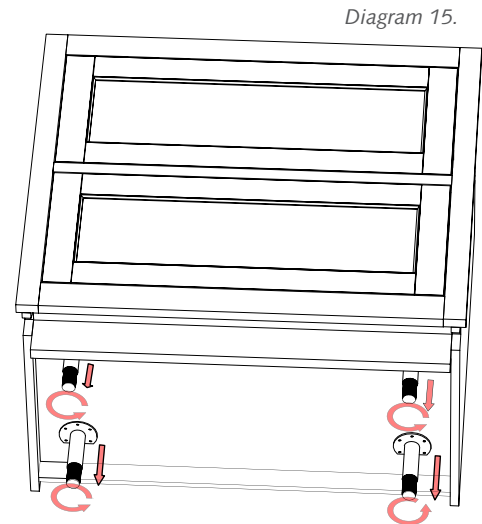
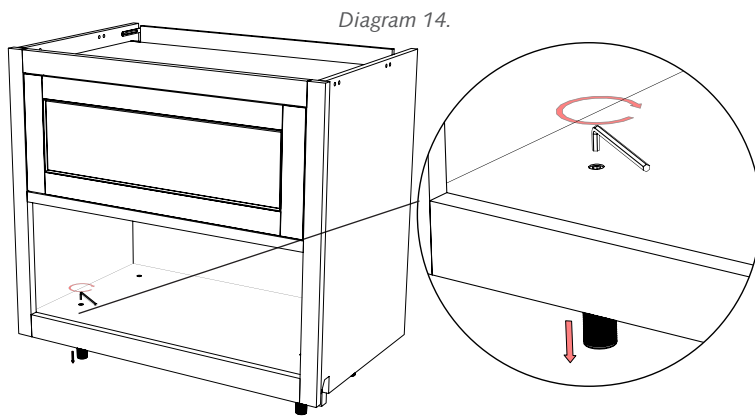

The Process;

1. Place the cabinet as near to its final location as possible.
2. Raise the entire cabinet & set height to 890mm from the floor at the lowest point in the room.
3. Continue to raise and lower each foot until the cabinet is completely level. This will need to be checked with a spirit level as shown in diagram 1.
4. You may find that you have to go back and forth between legs several times.
5. Levelling each cabinet fully is key to ensuring doors and drawers open and close freely throughout the life of the kitchen.

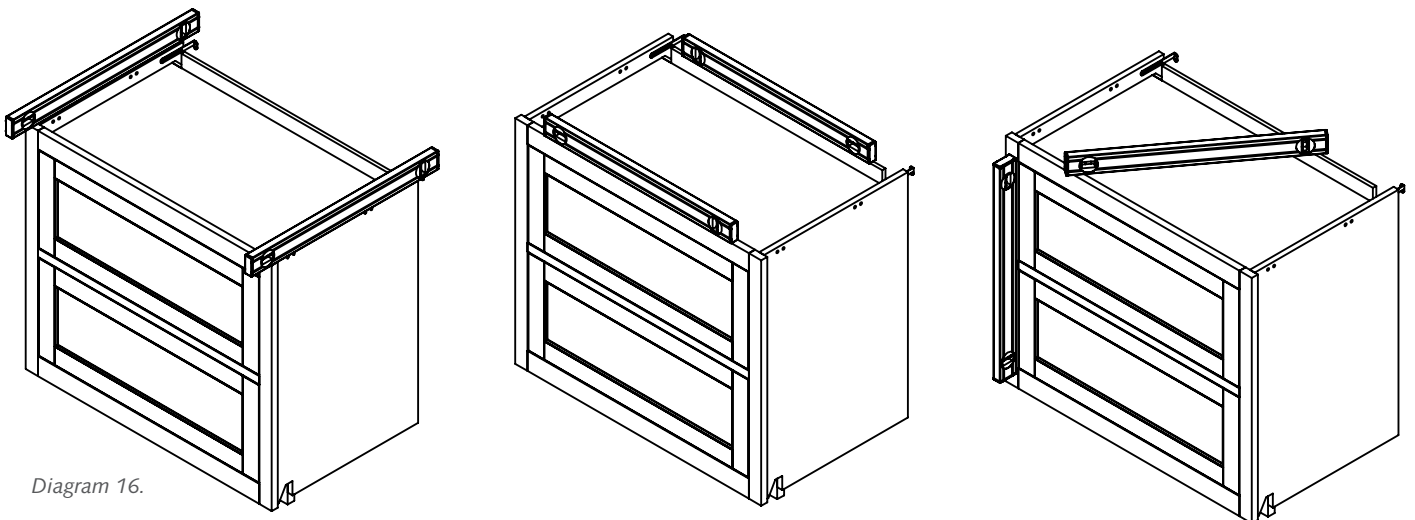

4. Offsetting

To make a feature of a particular kitchen cabinet it can be stepped out within a run. This is one of the unique features of a Neptune kitchen and allows for an individual kitchen design. This is often done with Sink cabinets but can be done using any base cabinet.

To off-set a cabinet simply bring it forward and bring the adjoining cabinets to the walls of the off-set cabinet. This will mean that the off-set cabinet is 22.5mm further from the wall, and the gap between cabinets is 12mm less.

An off-set foot kit is available to allow easy fitting of feet with offset cabinets.

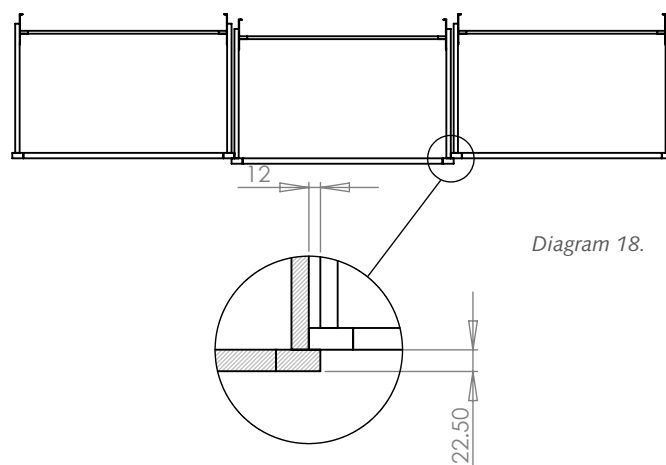
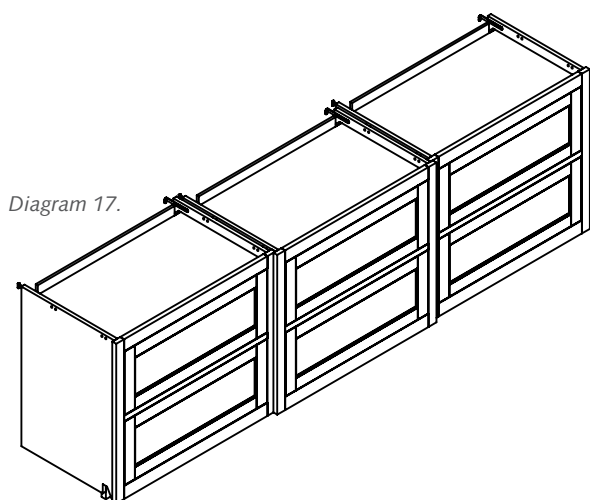

5. Attachment

Base Cabinet to Base Cabinet

Hardware is supplied to attach cabinets to each other. This enables the cabinet to be accurately and securely positioned allowing the join to be expanded or contracted. The front bolt is usually used to tighten the gap between cabinets. The rear bolt is usually used to ensure that the cabinets are parallel and that the front faces are straight.

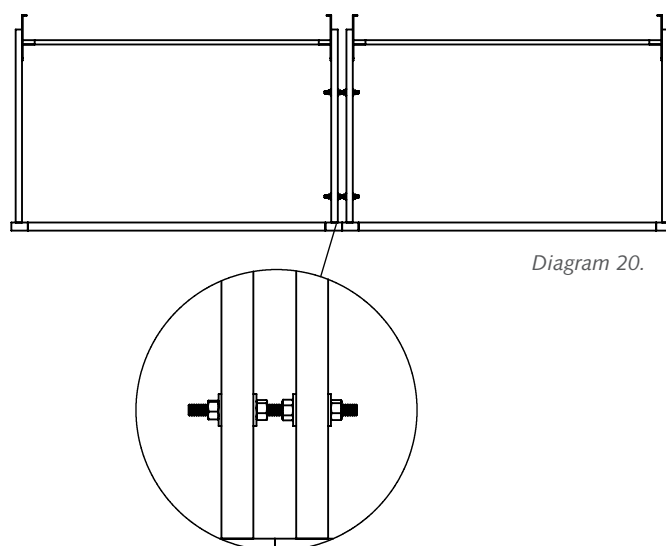
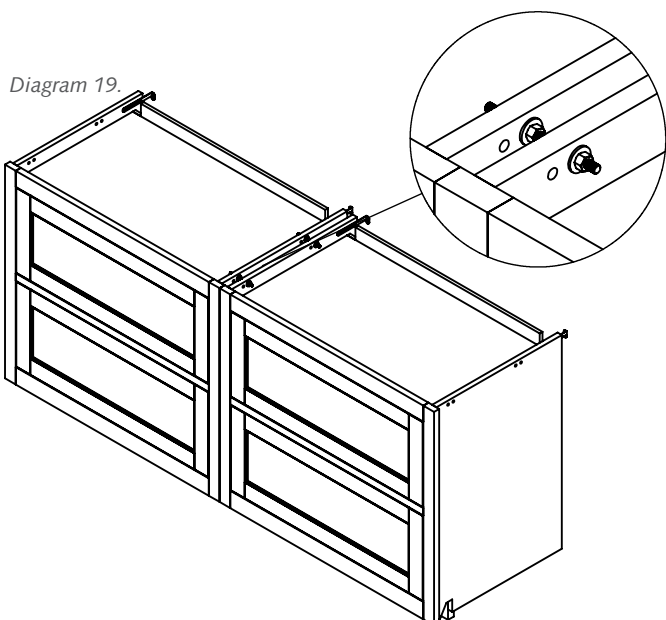

6. Feet Design

The feet are one of the unique features that give a seamless and bespoke look to the Henley kitchen. Feet can be positioned in a unique way for each kitchen design and schemes can be mixed in different areas of the kitchen. Below are examples of popular designs. Skirting board should be used with end panels for the return-to-wall in almost all designs.

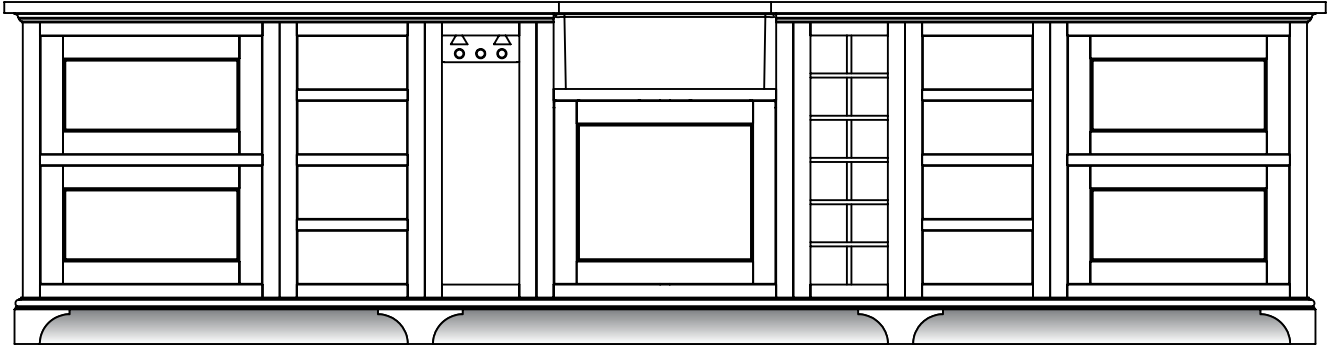

Diagram 21.

Example 1

Individual cabinets in the run have a recessed kickboard and their own feet, but not all cabinets.

Parts Used: 1 x Mitred foot left, 1 x Mitred foot right, 2 x Centre foot, Kick board, Lower moulding.

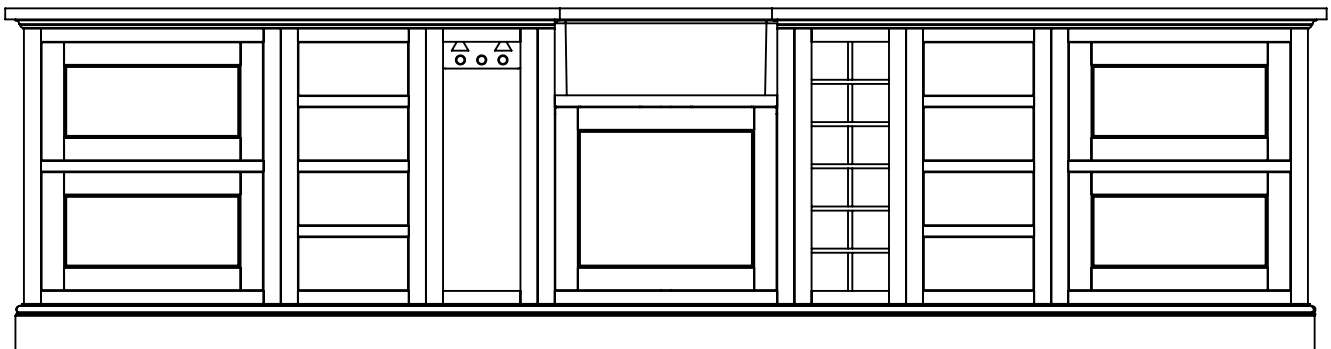

Diagram 22.

Example 2

Skirting board is run the full length of all cabinets.

Parts Used: Skirting board.

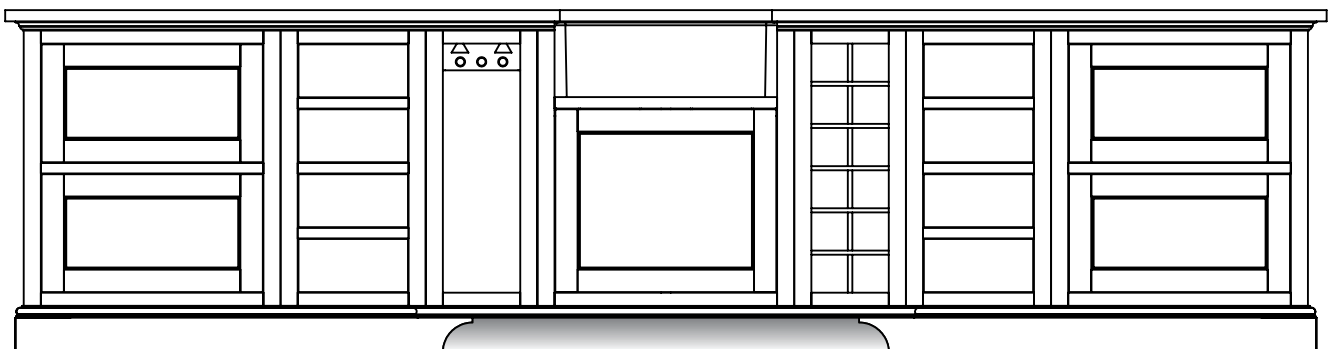

Diagram 23.

Example 3

A combination of skirting board, kick board and feet are used.

Parts Used: 2 x Mitred foot left, 2 x Mitred foot right, Kick board, Skirting board, Lower moulding.

Mitred left & right foot

These feet are used in two locations. The first is in conjunction with the Off-Set Kit. The second is at the end of a run when a mitred foot is required to join the end skirting board.

Centre Foot

Use this foot where a foot is required mid-run.

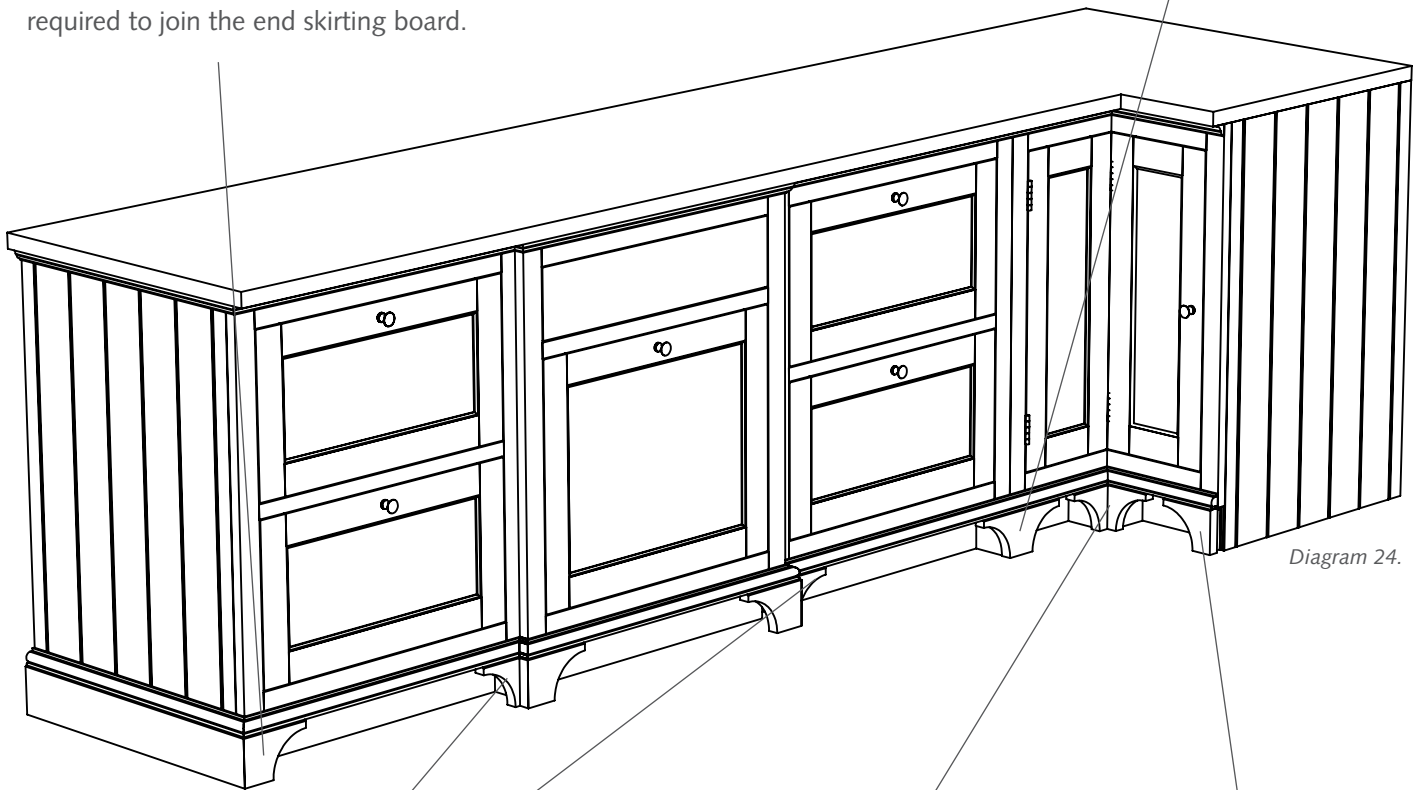

Diagram 24.

Corner foot

Use this foot for any corner cabinets or cabinets that join in a corner.

Off-set feet

Use this pair of feet where a cabinet is off-set. A pair of mitred feet will also be required.

Straight left & right foot

This foot is used where a flush finish to a run is required, for example where a range cooker is next to the run and there is no room for a skirting board return. In this case the extra scribing strip supplied with the end panel should be used to fill the gap.

Custom items

- The double sink cabinet is supplied with its own mitred feet, to match the thicker stiles on this cabinet.
- The freestanding island is supplied complete with feet.
- Curved cabinets are supplied complete with curved skirting, moulding and cornice where applicable.

7. Feet Fitting

This section shows how the feet are attached to cabinets.

1. The kickboard should be cut to length and scribed to any undulations in the floor. Screw the kick board to the cabinets through the pre-cut slots.

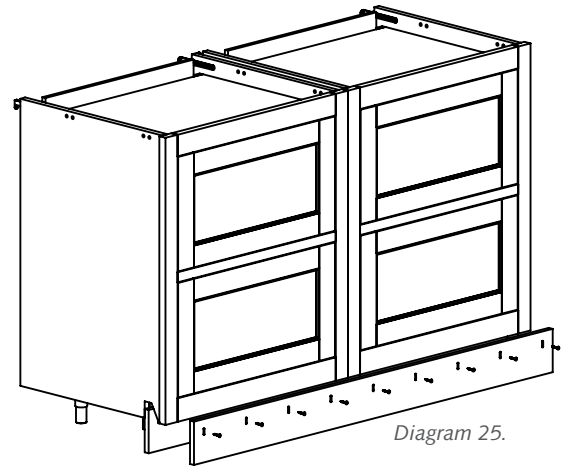
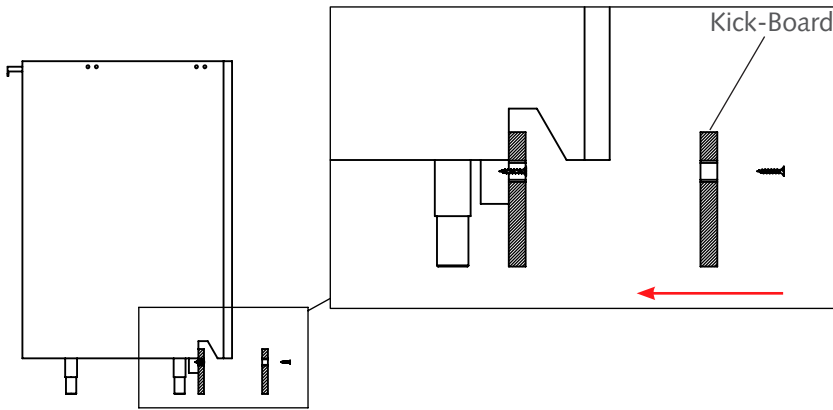

2. Screw a foot block into the kick board at each location where a foot needs to go.

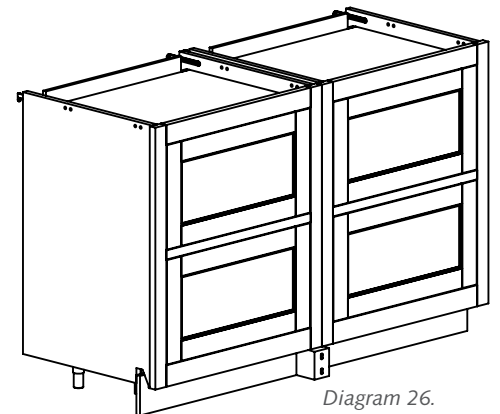
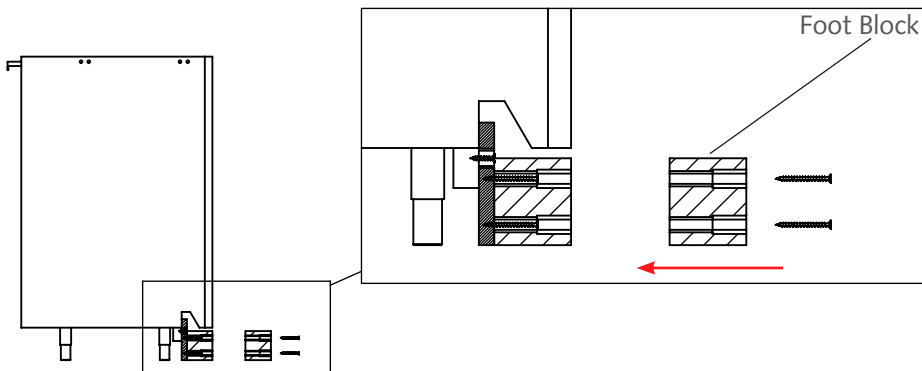

3. Locate the feet into the foot blocks, and test-fit with mouldings described in the next section.

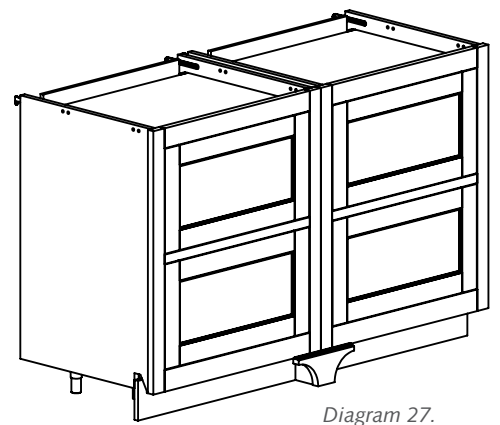
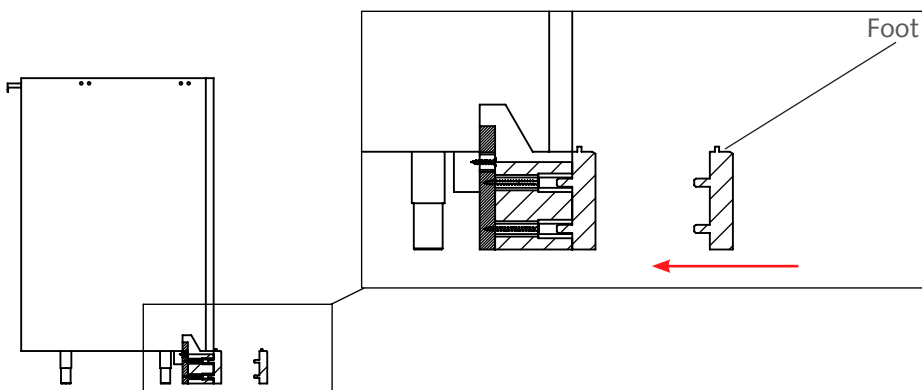

8. Mouldings

4. Cut the lower moulding to length and test fit on the feet. The lower moulding features a machined groove that fits onto a matching tenon on all feet. This ensures that the feet mate with the moulding correctly, matching the skirting board profile. There should be no gaps between the feet and moulding, and between the moulding and cabinet. When all components have been cut and test fitted they should be permanently attached. Feet should be glued to the feet blocks unless they are near an appliance which may be removed in future, in which case they should be fixed with industrial double sided tape or similar.

Lower Moulding

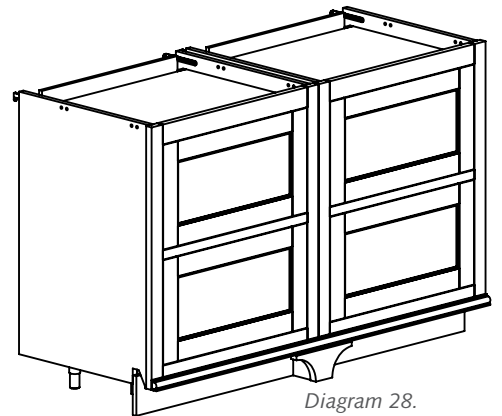
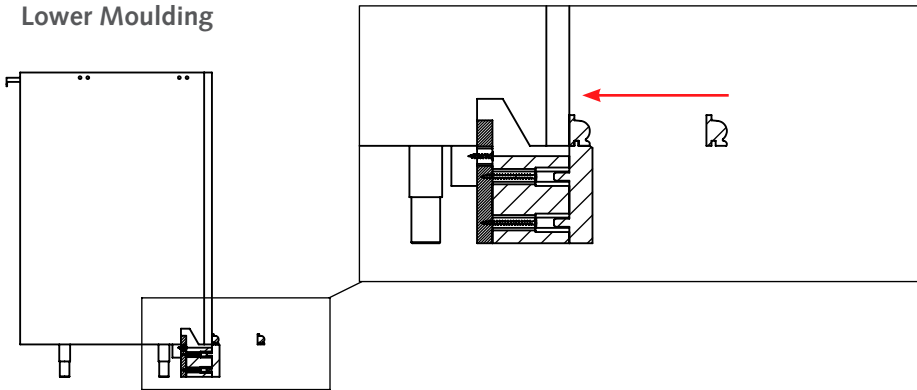

Diagram 28.

Mid Moulding

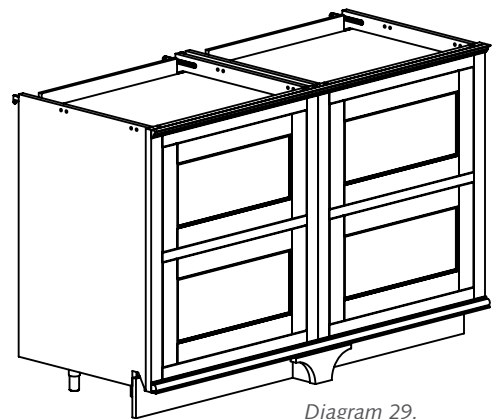
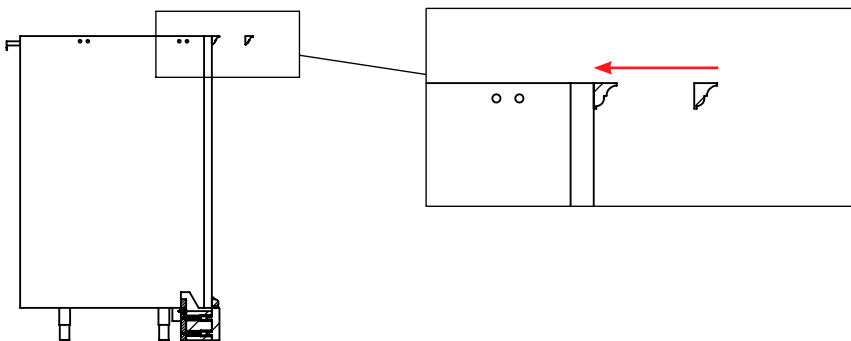

Diagram 29.

There are 3 ways to attach the mouldings to the base cabinets:

- The most convenient method of attaching the Henley mouldings is to use an air powered headless nail pin gun. These are available through specialist tool retailers or hire centres. They give a great finish as the head of the fixing cannot be seen.
- Industrial double sided tape is a good way of securing the moulding without glue or pins. It is especially useful in areas where a permanent joint is not desirable for example around an appliance that may need to be removed at a later date.
- The old ways are usually the best and so wood glue or contact adhesive can be used. This method takes more patience but is tried and tested.

All curved mouldings are supplied oversized to allow for scribing to un-even walls.

It is vital that sharp tools are used to cut mouldings whilst paying attention to the direction of the wood grain. Mitre joints can be sanded very finely by hand to get a perfect finish without removing the finish on the oak.

9. Skirting Board

Skirting should be used at the end of all kitchen runs where there is a return to wall, unless a flush finish is required. (shown on page 9) Skirting board can also be used in longer lengths instead of feet depending on the desired look of the kitchen.

10. Lighting

Glazed wall cabinets are supplied with fitted downlights. The lights supplied are 12V MR11 down lights. When replacing bulbs the rating should not exceed 35W. Connect the Henley lighting to a dimmable switched circuit for the best result.

11. Larders

All Henley larders are supplied with a space to allow for a worktop to be installed inside the cabinet. This is set at the same height as the rest of your worktop to give a great seamless look throughout the kitchen. Your worktop supplier will be able to fit this.

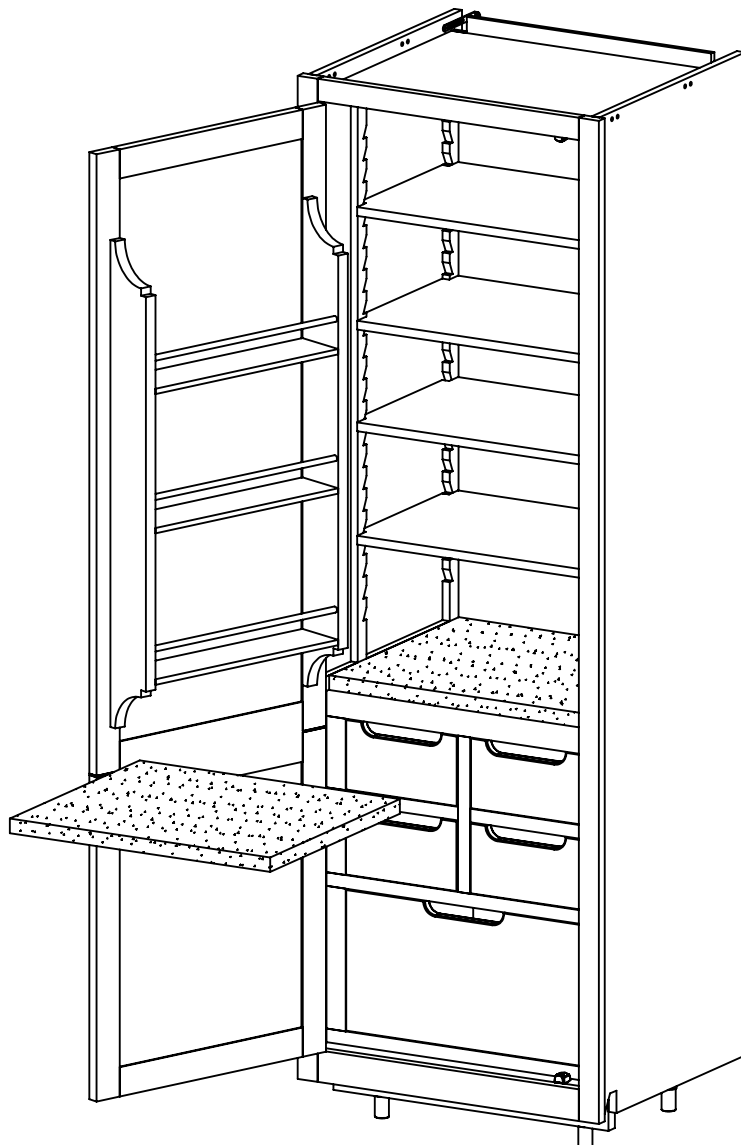
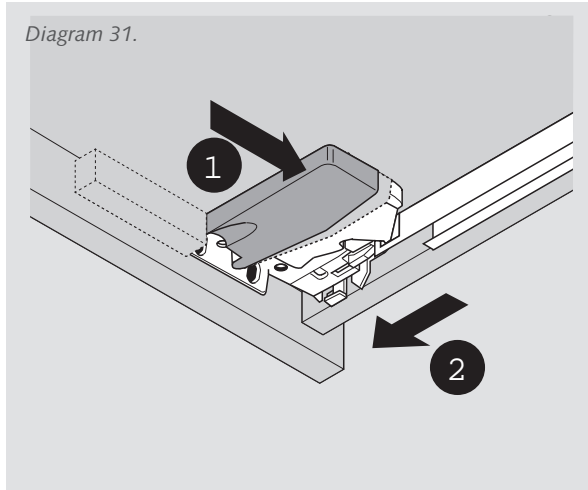

Diagram 30.

12. Drawer Removal & Adjustment

Henley Kitchen drawers are supplied with double extension soft close Blum drawer runners that support up to 30Kgs. These runners enable the removal of the drawer box via quick release orange toggles found on the underside of each drawer at the front corner. (NB There are 4 catches on each drawer on a 1250 Pandrawer) The drawer box can also be adjusted in height and tilt to ensure perfect running and correct gap between carcass and drawer front.

Removal



Squeeze both toggles (1) with a hand either side of the drawerbox.

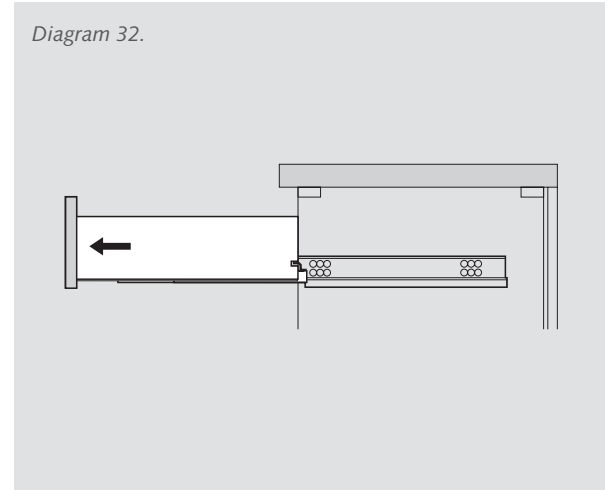

Remove the drawer by sliding it out (2)

Insertion

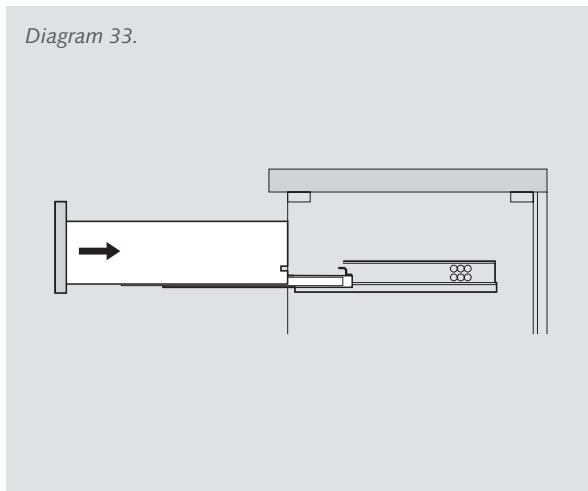

Extend the runners and place the drawer on them

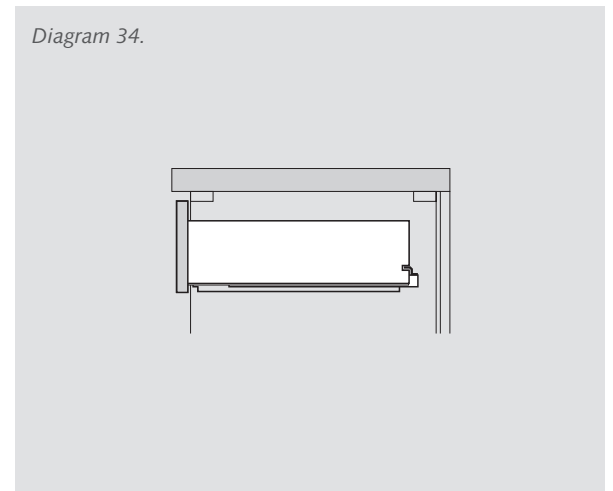

Push the drawer into the cabinet. The catches will both click when engaged.

Adjustment

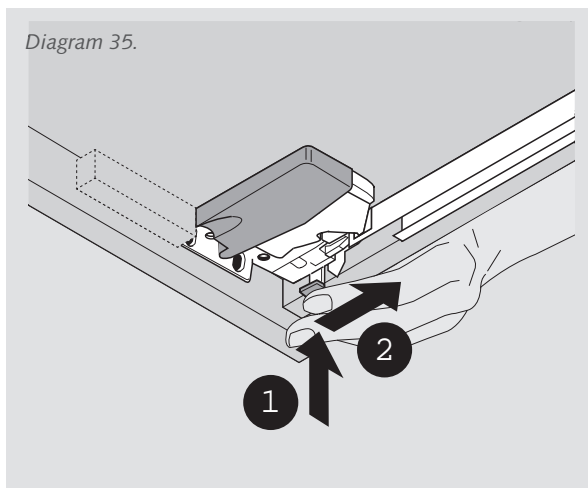

Front face Height adjustment: + 3 mm

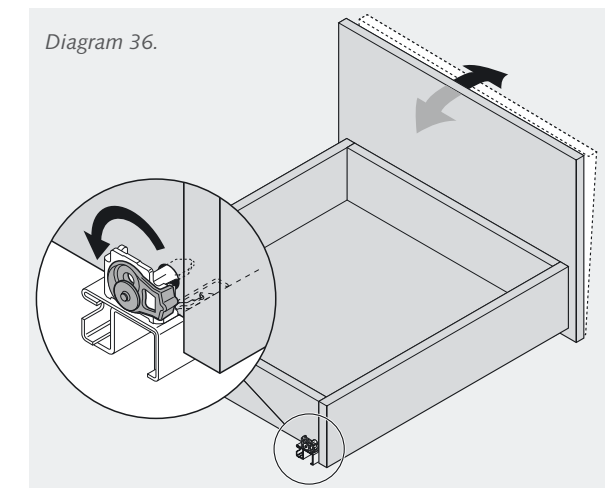

Tilt adjustment, found at the back of the runner.

13. Appliances

The Henley kitchen is fully framed and so the cavities have been carefully designed to fit appliances precisely, without any adjustment in most cases. For this reason Neptune recommends Neff, Bosch, & Siemens appliances.

1050 Full Height Appliance Cabinet

This cabinet is designed to hold appliances in 3 different configurations:

1. 600 Single Oven & 450 Compact appliance (including coffee machine) above.
2. Single warming drawer & Double oven above.
3. 600 Single Oven & Microwave above.

In order to use the same cabinet for different configurations the shelves are interchangeable.

An extra baton is attached to one of the shelves. This is to allow for a slightly different sized appliance. The extra baton can be planed to the correct size if required giving an adjustment of + 10 or - 20mm from the standard aperture height.

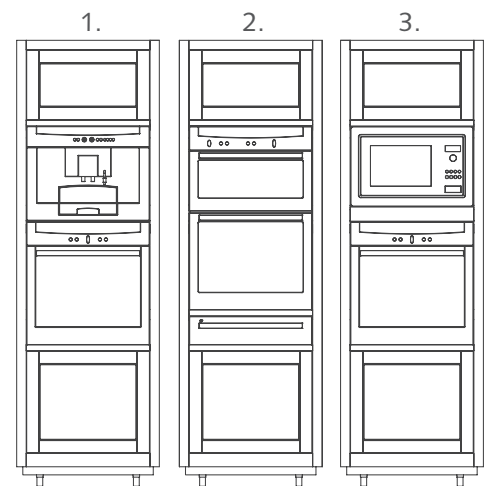

Diagram 37.

600 Full Height Appliance Cabinet

This cabinet is designed to hold appliances in 2 different configurations:

1. 600 Single Oven.
2. Single warming drawer & 450 Compact appliance.

An extra baton is attached to the top shelf. This is to allow for a slightly different sized appliance. The extra baton can be planed to the correct size if required giving an adjustment of + 10 or - 20mm from the standard aperture height.

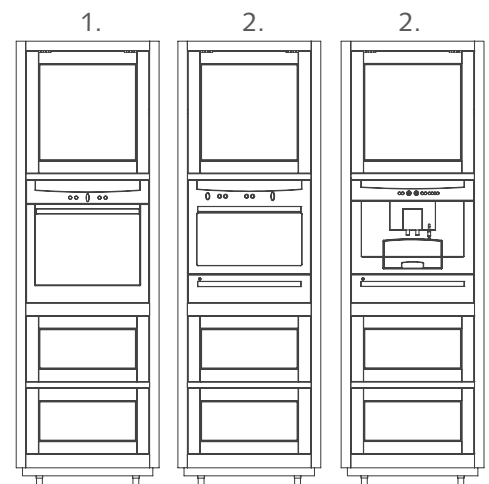

Diagram 38.

Under-counter appliances

We recommend that under-counter appliances (washing machine, dishwasher, fridges, freezers) are fitted mid-run in accordance with manufacturer's instructions. Fitting at the end of a run is possible, but will require some extra support which will need to be constructed by the kitchen fitter. Often an Island foot is used at the end of a kitchen run next to an appliance to increase stability. Speak to your Neptune kitchen designer for advice on possible options.

14. Handles

Henley cabinets are fitted with Antique brass door hinges. A matching Henley handle has also been designed in the same finish to complement the Henley oak colour.

Chrome replacement hinges are available to match other finishes of handle. Contact your Neptune dealer for more information.

Handle Positioning

Fitting the handles is a key step in finishing the look of a Neptune cabinet. It is very important that they are fitted correctly as it is very hard to correct poor positioning. Below are recommendations for positioning handles for the classic look.

Single handle drawers

Neptune recommends handles to be placed in the vertical and horizontal centre of solid fronted drawers. For framed drawers the handle is usually mounted in the centre of the top frame.

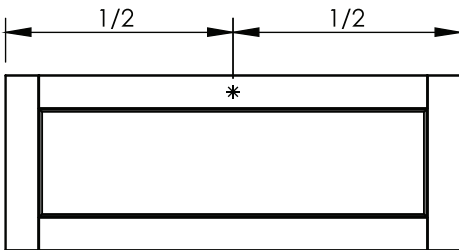

Diagram 39.

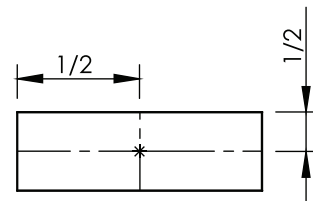

Diagram 40.

Double handle drawers

Two handles are positioned along the top frame of the drawer panel and following the quarter, half, quarter rule.

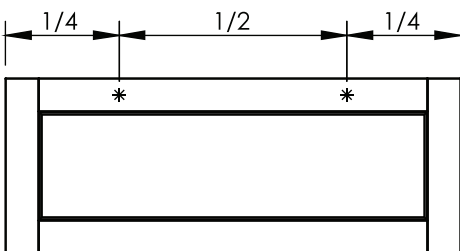

Diagram 41.

Doors

Neptune recommends that the handle is placed in the vertical centre of doors, and in the centre of the frame.

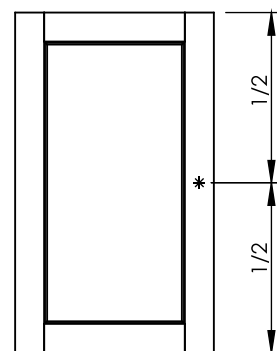

Diagram 42.

Handle Fitting

Handles should be fitted after the kitchen cabinets have been installed. The first drawer handle position should be measured and fitted as above. Subsequent drawer handles should be fitted relative to the first drawer. The vertical position of the handles should be made using a spirit level or measured depending on the particular layout of handles. When drilling the drawer front for the handle screw, care should be taken to use a suitable drill bit and speed so the wood is not damaged at the back of the hole. For a perfect result hold a piece of sacrificial wood onto the back of the drawerfront while drilling to avoid breakout.

15. Care & Maintenance

The Henley kitchen uses a proprietary Neptune finishing process to achieve a classic *washed* look that is exclusive to Neptune. Each cabinet is finished in the same way and to the same standard in our workshop. For this reason the Henley kitchen cannot be re-finished to its original condition. Bear this in mind if modifying cabinets as any fresh exposed oak will look different to the rest of the kitchen.

Neptune supplies a colour matched Hard Wax Touch Up Kit (Neptune code: HENK-ACC-072), that can be used for repairing small areas. This is especially useful to cover pin heads for example, and is recommended for each kitchen fit.

Some cabinets have parts that are designed to be modified such as end panels, and shelf framing on some full height cabinets. When sanding or cutting it is important to only remove material from surfaces that will not be seen. When a part has been sanded it should be sealed to prevent it from drawing in ambient moisture from the air.

16. Contact Information

If you have any questions regarding the fitting of your kitchen please feel free to contact us.

Neptune Classics

Unit 2, Lydiard Fields

Swindon

Wiltshire

SN5 8UY

t : 01793 881144

f : 01793 881155

e : info@neptune.co.uk

w : www.neptune.co.uk