

ESSE

Ironheart

Models EW & EWB

Wood Fired Cooking Stove

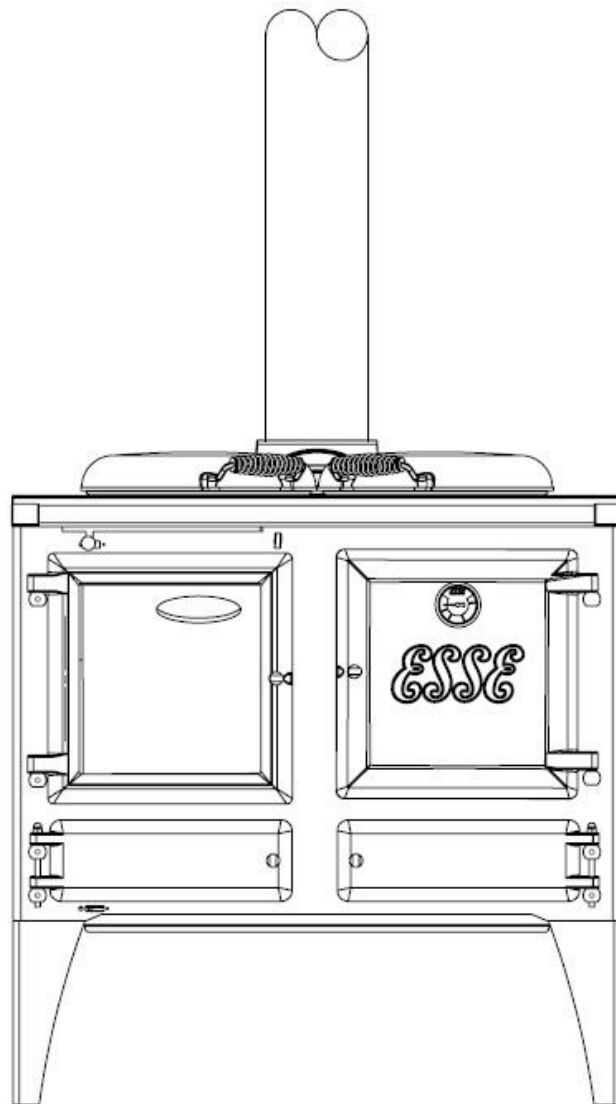

THIS APPLIANCE MUST BE COMMISSIONED BY A HETAS REGISTERED ENGINEER

THE WARRANTY CARD MUST BE RETURNED TO ENSURE GUARANTEE VALIDITY

CE



Table of Contents

OPERATING INSTRUCTIONS	3
INTRODUCTION.....	3
BEFORE USING YOUR COOKING STOVE	3
YOUR COOKING STOVE	4
LIGHTING AND CONTROLLING THE FIRE.....	6
NOTES ON WOODBURNING	10
LONG TERM SHUTDOWN	11
FIREWOOD AND THE WOODBURNING PROCESS.....	11
COOKING WITH THE COOK STOVE	16
EXTENDED WOODBURNING.....	18
CLEANING AND MAINTAINANCE	19
CONDITIONS OF GUARANTEE	21
EXCLUSIONS.....	21
CUSTOMER CARE	22
SAFETY NOTES.....	22
INSTALLATION INSTRUCTIONS	24
GENERAL SAFETY INFORMATION	24
DIMENSIONS AND CLEARANCES	25
CHIMNEY AND FLUE INFORMATION	26
INSTALLING THE APPLIANCE	29
HOT WATER SYSTEM (EWB MODELS ONLY)	31
COMMISSIONING THE APPLIANCE	33
REPLACEMENT PARTS	34
COMMISSIONING CHECKLIST	36
TECHNICAL INFORMATION.....	37



Ironheart

OPERATING INSTRUCTIONS

INTRODUCTION

Thank you for choosing an ESSE cooking stove. Please read these instructions carefully to ensure your safety and enjoyment whilst using this product. Correctly installed and operated, your ESSE cooking stove will provide faithful service indefinitely. We feel certain that like countless ESSE owners since 1854, you will be truly satisfied by the warmth and comfort it will provide and the taste of your food cooked within its oven.

BEFORE USING YOUR COOKING STOVE

Ensure that any protective packaging used to protect surfaces has been removed. The hotplate has been oiled at the factory to prevent rusting and therefore will require wiping with a damp cloth and drying with a tea towel or kitchen roll.

During the first few operations of the cook stove there may be some ticking and fumes emitted. This is normal and part of the initial expansion & material curing process.

YOUR COOKING STOVE

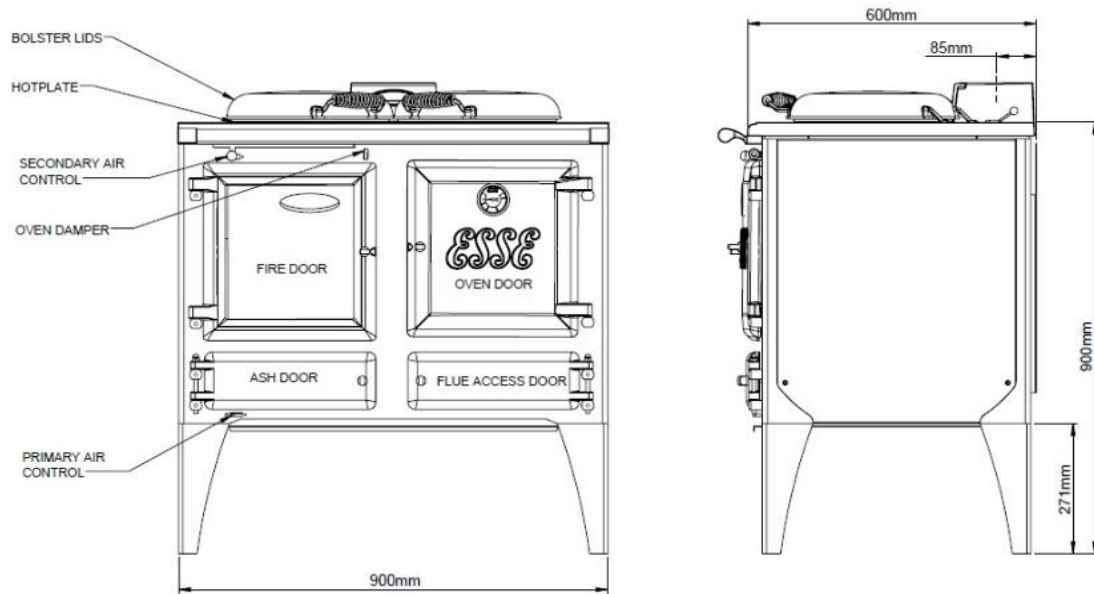

Figure 1 Ironheart Cooking Stove

Figure 1 show the cooking stove and it's controls. The fire is loaded, refuelled, and emptied through the large glass fire door.

A flue damper is fitted in the bottom of the flue box and is in the open position when lever is pointing to rear of cooker. This is used on initial light up and also gives a cooler oven temperature when open. It can also help to control excessive flue draught. This is done by pointing the lever to the front of the cooker.

The controls are operated in the following ways:

Primary Air Control	Slide LEFT to open
Secondary Air Control	Slide LEFT to open
Oven Damper	Turn ANTI-CLOCKWISE to open
Flue Damper	PUSH back to open

Included inside your cooking stove is a multi-purpose Operating Tool – for adjusting the air supply and operating the door. A glove is also provided to protect the user’s hand. (Figure 2)

WARNING

Do not place towels on the handrail, keep pets and children away and ensure that any curtains near the appliance cannot ignite even when displaced.

Surfaces will be hot when in use.

An extractor fan **MUST NOT** be fitted in the same room as the appliance.

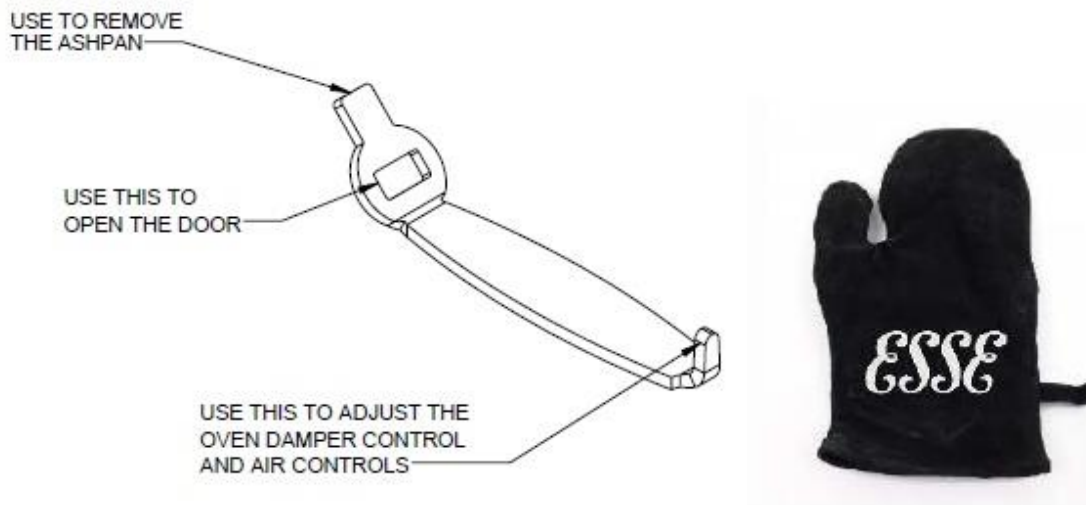

Figure 2 Operating Tool and Glove

LIGHTING AND CONTROLLING THE FIRE

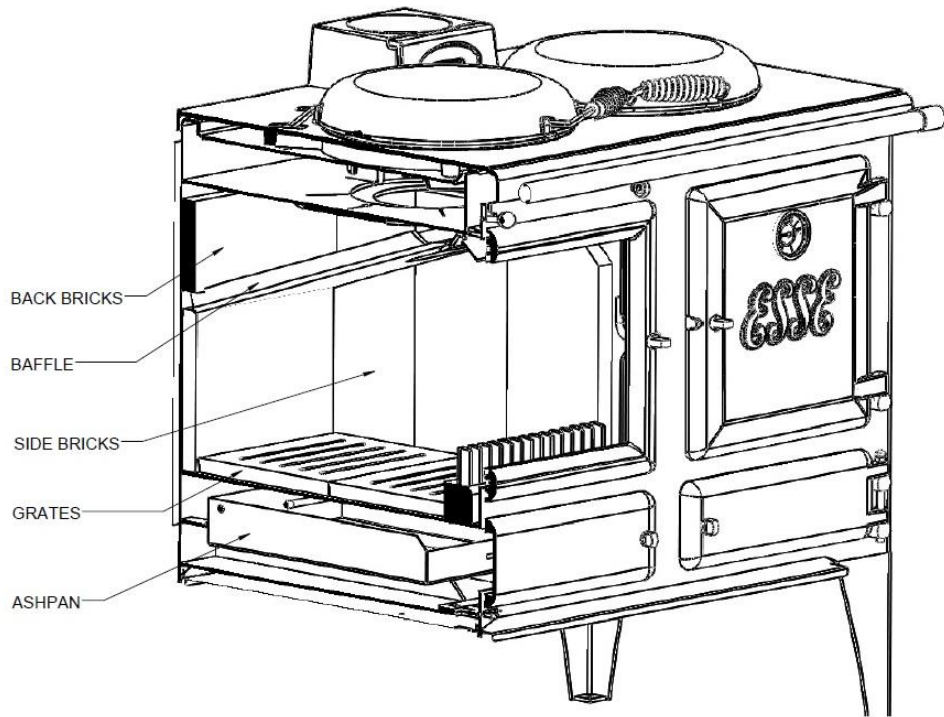

Figure 3 Multi-fuel Grate Firebox Parts

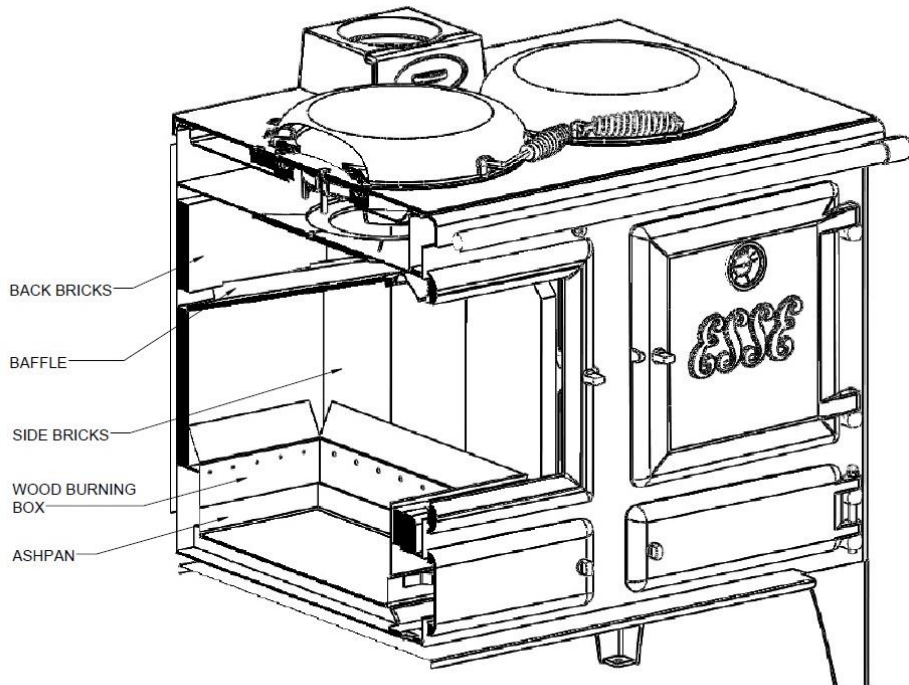

Figure 4 Wood Burning Firebox Parts

Before lighting the fire ensure that all parts are in the correct position. For multi fuel use see Figure 3.

The Ironheart may be configured to a wood burning only specification by removing the grate and ashpan and substituting a steel wood burning box (see Figure 4). This increases the firebox volume and by facilitating an ash bed can extend reloading intervals.

Ensure both air controls are in the open position by moving the controls to the LEFT, the oven damper is opened by rotating the control ANTI-CLOCKWISE, and the flue damper opened by pushing the lever tot the REAR of the cooker.

Open the fire door and lay two logs along the base of the fire box forming a space between them.



Figure 5 Logs Laid in Fire Box

Place a firelighter in the space and surround with a small amount of kindling.



Figure 6 Fire Lighter and Kindling in Place

Lay a third log over the top of the space perpendicular to the other logs.



Figure 7 Final Log in Position

When you are ready to light the fire all that needs to be done is light the firelighter.

Once the fire has been lit leave the door partially open to allow additional airflow until the fire has become established. When the fire is established the fire door can be fully closed. The air controls can be moved towards the closed position once the sooting has burnt off the brickwork. To control the fire when burning wood the secondary air control should be used, the primary air control should be kept closed. The primary air control should be used when burning smokeless fuels with the secondary control kept open where possible to prevent the window sooting up.

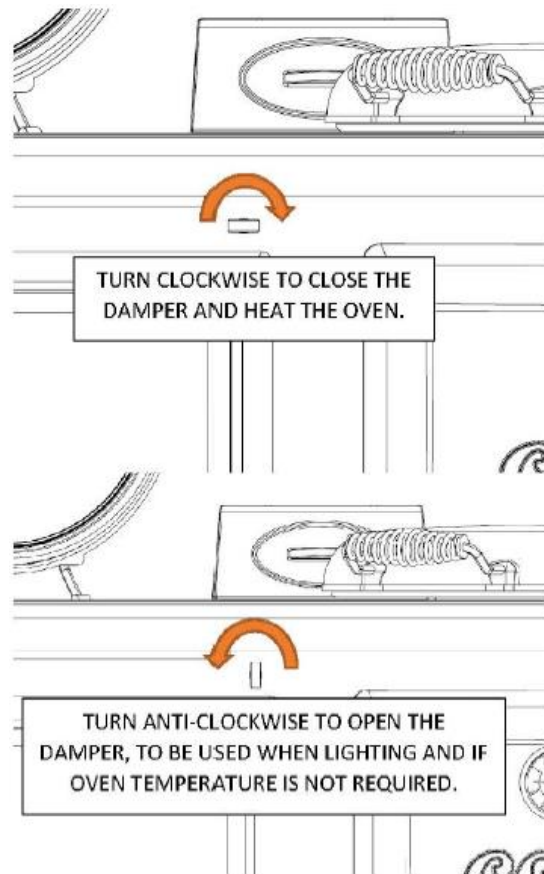

Figure 8 Oven Damper Controls

Once the fire has been established the oven damper control may be used to regulate the oven temperatures along with the burning rate of the cookstove.

WARNING

When the cooking stove is running ALL HANDLES become hot and the operating tool or glove provided should be used to open or close the doors (Figure 2)

The burning rate of the stove can now be regulated by the rate at which fuel is added and use of the air control. The maximum amount of fuel to be loaded during normal operation is 2kg per hour in order to achieve nominal heat output.

NOTE

This appliance is not an incinerator and only dry well seasoned wood or approved fuel should be used.

If the cook stove is being used primarily to heat the room it is recommended that the bolster lid is kept in the raised position to allow heat from the hotplate to radiate into the room.

When refuelling the cook stove it is recommended that the logs are placed running front to back as in Figure 5 as this leads to the cleanest combustion.

Before lighting a full fire in the cook stove for the first time it is recommended that 3 smaller fires are lit first to ensure that any moisture is driven out.

WARNING

EWB MODEL ONLY: Do not light the cook stove if there is a possibility that any part of the boiler loop is frozen.

NOTES ON WOODBURNING

Wood burns most efficiently when the air for combustion is supplied from above the fire bed. This air supplies the oxygen necessary for the volatile gasses given off by the wood as it is heated to combust which increases efficiency and reduces heat being wasted up the chimney.

Running the cooking stove with the air control open will provide oxygen for the wood to burn on the fire bed and should be used to control the fire when lighting or refuelling. The cooking stove should ideally be run with the air control in the closed position for the majority of the time in use. If the fire appears to die down too low then opening the air control slightly for a short period can help revive it.

To get the best results from your cooking stove it is recommended that a wood stove thermometer be fitted to the flue pipe above the cooking stove. This allows you to monitor the temperature of the flue gasses leaving the cook stove.

Below 115°C

This is below the condensation point of wood gasses and may cause the build-up of tar in the chimney, dirty the fire door glass and result in the inefficient burning of fuel.

115°C – 260°C

The flue gasses should be in this temperature band for the safest, most efficient operation of your cooking stove.

Above 260°C

Too hot. Heat will be wasted up the chimney. Excess heat may damage the cooking stove or ignite an existing accumulation of tar resulting in a chimney fire. In the event of a fire, close the air controls on the appliance and call the fire brigade for assistance.

LONG TERM SHUTDOWN

If the cooking stove is to be shut down for long periods i.e. during summer months or if the appliance is in a second home that is not used all the time, precautions should be taken to avoid damage from condensation and corrosion.

First ensure that the cooking stove is fully cleaned and all ash removed. The ovens and hotplate can then be treated with a light coating of flax oil to help prevent moisture damaging the surfaces. The air control is to be left in the open position, the doors slightly ajar, and the bolster lid left raised to allow for ventilation.

FIREWOOD AND THE WOODBURNING PROCESS

Seasoning and Storing Firewood

Wood, which has recently been cut and is still full of sap and water is known as "green" wood.

Green wood will generally burn poorly and inefficiently, because it can have over 50% water in its cells. It may be hard to light, smoulder, not put out any heat and cause more than the usual amount of creosote to build up in your chimney.

So your aim should be to dry the wood out to below 20% moisture content, this process is called seasoning. As the name implies, you should store your wood for a season or so, while it dries, but there are things you can do to speed up seasoning by cutting the wood now rather than just before you use it.

Wood is composed of bundles of microscopic tubes that were used to transport water from the roots of the tree to the leaves. These tubes will stay full of water for years even after a tree is dead. This is why it is so important to have your firewood cut to length for 6 months or more before you burn it, it gives this water a chance to evaporate since the tube ends are finally open and the water only has to migrate a small distance to escape. Splitting the wood helps too by exposing more surface area to the sun and wind, but cutting the wood to shorter lengths is of primary importance.

Here's how you can tell whether your wood is ready or not: Well seasoned firewood generally has darkened ends with cracks or splits visible, it is relatively lightweight, and makes a clear "clunk" when two pieces are struck together. Green wood on the other hand is very heavy, the ends look fresher, and it tends to make a dull "thud" when struck.

Another thing you can do to help is store your wood properly. Store it off the ground by building the pile on some longer logs (or whatever method you can devise). A shed or shelter with an open side makes an ideal storage place, as the air can circulate around the logs and help to dry them out. Unventilated spaces or plastic tarps, which never get taken off will prevent the drying and evaporation process and cause moulds and rot. So, if a tarp is your only option, take it off frequently to air the wood on fine days. And remember to put it back on again. Seasoned firewood will reabsorb large amounts of water if exposed to rain, snow and excessive dew, which is liable to make it rot and be unfit for making a good fire.

When you build up a store of firewood, remember that the wood may start to deteriorate after 4 to 5 years, although this is of course variable and depending on storage conditions and species involved.

What Type of Wood is Best?

The difference between 'hard' and 'soft' woods is the density of their cells or fibres.

As a general rule, the deciduous trees (those that lose their leaves in the autumn) are usually thought of as hardwoods and the evergreen trees (such as pines, firs and larches) as the softwoods. But generalisations are of course always subject to many exceptions. Some evergreens may well be harder than

some deciduous trees. Birch, for example, is not very hard at all. So we should understand that there is a whole range of densities amongst our tree species, including medium dense woods, which cannot be satisfactorily classed as hard or soft.

Firewood tends to be sold by volume rather than weight. Assuming that the wood is reasonably dry, the weight of a square metre of good hardwood may be double of that of a square metre of softwood. This means that the same volume of hardwood will provide you with more fuel to burn than an equal amount of softwood, simply because it contains more substance.

(N.B. The price of hardwood will normally not be double that of softwood, because it took the same amount of labour to prepare. So, if a trailer full of hardwood costs more than the same size trailer full of softwood, the more expensive option may well be the most economical.)

The other advantage of good hard firewoods are that the cooker does not need to be fed as often and the charcoal-beds made by the glowing wood may burn more easily overnight.

However, the ideal situation would be to have a store of both hard and soft woods, because the softer woods also have distinct advantages. They light more easily than the slower burning hardwoods and if the softwoods are dry, they create a hotter, more intense fire. The draught created by the hotter fire moves the air up the chimney faster.

After reading the notes opposite about the burning process, you will understand that means less pollution in the form of smoke and less creosote condensation in your chimney.

The denser hardwoods tend to smoulder more easily when the fire is first lit, so their flue gas temperature will be much cooler.

Because softwoods like pine and larch contain a lot of resins and pitch, a popular misconception is that they will fur up the chimney with creosote more easily than a hardwood like oak. This is not necessarily true at all. It is not the pitch that is the problem, it's the water IN the pitch. Once the water in the wood has evaporated, that pitch becomes high octane fuel. When dry, softwoods burn extremely hot.

There is also the matter of seasoning to be considered. When you buy wood, it will usually have been cut in the winter of the year you buy it. Hard woods tend to take longer than softwoods to fully dry out.

Softwoods cut in the previous winter should, with proper storage, be ready to burn the next autumn, whereas many hardwoods may take a bit longer than that. Oak, for example, is very slow to dry out and ideally left for two years. It is also possible to purchase pre seasoned wood or kiln dried wood.

Summarising we can say that it is always sensible to buy this year for next years fuel supply and that it is very handy to have both soft and hardwoods. You can use the softwoods to start a good fire and you will have additional control over the fire (in addition to the cookers controls) by adding slower burning wood to fast ones if you want to leave the cooker without tending it for a while. Alternatively you can add some fast burning softwood logs to the slower hardwood logs to instantly revive a fire, which has been neglected.

The Wood Burning Process

Understanding what happens when wood is burnt will enable you to burn wood in a more environmentally friendly way, reduce the maintenance required for your chimney and get more out of your wood. There are 3 stages in the wood-burning process:

Evaporation

When you light the cooker a lot of energy will be needed at first to boil away any moisture, which is left in the wood. Using energy to drive off excess water in firewood robs the cooker of energy needed for an efficient and clean burn. Also, much of the energy wasted in evaporating water is energy that could have heated the hotplate and oven. This is a waste of wood, money and effort. The presence of all that moisture tends to keep "putting out" the fire, and therefore making it burn very poorly, which tends to produce a lot of creosote and pollution.

Emissions

As the heat of the fire intensifies, waste-gases (smoke) are released from the wood.

Unburned smoke is emitted into the air either as pollution, or condensed in the chimney causing creosote build-up. It takes time for the air in your chimney to heat up. When it is still cold you get an effect similar to the condensation of hot

breath on a colder window or mirror. So when the by-products of combustion (smoke in the form of gases) exit the cooker, and flow up into the relatively cooler chimney, condensation occurs.

The resulting residue that sticks to the inner walls of the chimney is called creosote. Creosote is formed by unburned, flammable particulates present in the smoke. It is black or brown in appearance. It can be crusty and flaky, tar-like, drippy and sticky or shiny and hardened. Quite often, all forms will occur in one chimney system.

If the wood you are using is water logged, or green, the fire will tend to smoulder and not warm the chimney sufficiently. Wet wood causes the whole system to be cool, and inefficient. In contrast: dry wood means a hot fire, which results in a hot flue, and a hot flue means much less creosote clogging up your chimney.

The cooker's firebox is designed to operate at very high temperatures to burn the gases and particles released from the wood, which means less air-pollution.

Charcoal

When most of the tar and gasses have burned the remaining substance is charcoal (ash in it's finer form). A hot bed of charcoals and ash can enhance the combustion process when burning larger pieces of wood. Start with a small fire to develop a bed of glowing embers. As the charcoal bed develops and the cooker heats up, slowly add larger and larger pieces of wood. It takes time to build a good charcoal bed, but it is well worth the effort. Only empty excess ash periodically and always leave a bed of ash on which to light the next fire. When wood burns it gives off volatile gases which contain calorific heat value.

Peat

Peat is a fuel conveniently available in some areas and should be burned in the same manner as wood.

Ash Removal

Wood burns best on its own ash and a manageable layer of ash on the grate is a benefit to the efficient running of your cooking stove. To empty the ashes from the ash pan below the grate, open the door at the bottom left of the cooking stove using the Operating Tool by connecting the tool to the door handle and turning anti-clockwise. Insert the tool into the slot on the ash pan and pull forwards and lift to remove. Care should be taken when disposing of ashes that

are still warm. They should not be put into a plastic receptacle or anything that might melt in contact with heat.

Always use the Operating Tool to open the ash door and remove the ash pan. Use the Operating Tool to securely lock the door and ensure the door is closed properly.

NOTE

The above text is a guide only. The ideal operation of your cooking stove depends on a number of factors which vary with each installation. Gaining experience on your cooking stove is the only way to learn its best operation.

COOKING WITH THE COOK STOVE

The oven and hotplate are heated directly by the fire. In order to heat up the oven and hotplate, the fire should be lit as described on page 7.

The temperature of the hob is graduated from left to right. The left side is hotter and so is used for boiling and the right side for simmering. The oven door and the fire door are opened by lifting the handle either manually or using the Operating Tool provided.

The oven and hob are heated directly by the fire. In order to heat up the oven and hob the fire should be lit as described above. Once the fire is established the oven damper should be turned clockwise to close. This will allow the hot fumes from the fire to circulate around the inner cavity between the cooking stove and the oven thus heating up both the hob and the oven.

The hob lids can be left down when the hob is not being used in order to keep the hotplates warm. In the up position they will allow more heat into the room.

To reduce the heat going to the oven when the cooking stove is up and running, the oven damper knob can be turned anti clockwise. This will allow the hot fumes to escape directly up the chimney via the boiling side of the hotplate, thus reducing the heat to the oven but maintaining a hot hotplate.

To maintain a good cooking temperature in the oven the cooking stove requires only a small amount of fuel. With the multi-fuel grate, to reduce the effective size of the firebox, the fuel bar can be moved towards the back and thus used

to hold a smaller amount of fuel at the rear of the firebox. This also has the advantage of reducing the heat radiated through the window, making life easier for the cook. Also the fire guard can be slid in front of the fire door in order to reduce the heat through the glass and protect the operator whilst cooking.

The temperature gauge on the oven door provides an indication of the oven temperature. It should be noted however that since the gauge is attached to the door, the indicated temperature will drop if the door is left open for any prolonged period, in which case, the oven may be hotter than it is indicated on the dial. Once the door is closed again, the gauge will come back to temperature.

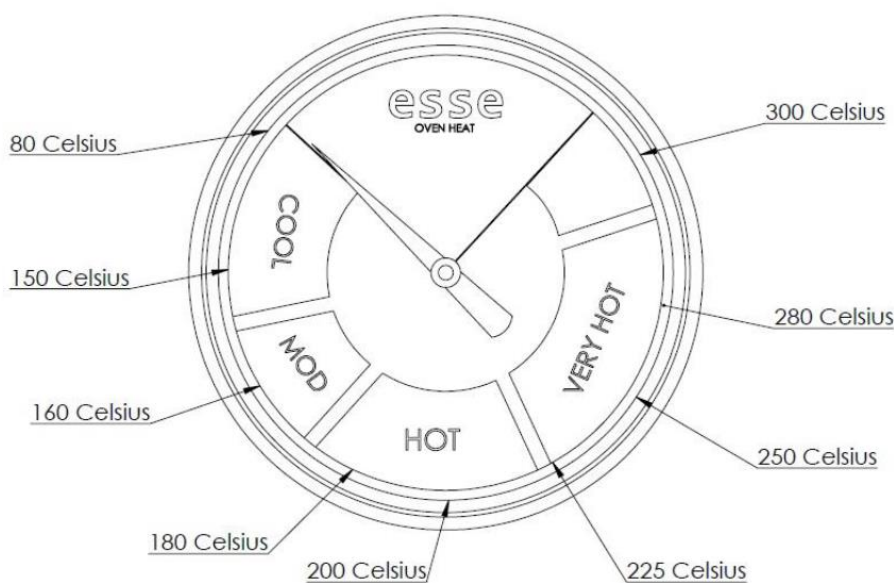

Figure 9 Temperature Gauge Temperature Guide

The oven is equipped with a wire shelf which can be set to the desired height. The shelf has anti-pull out stops to prevent it from being pulled out inadvertently; to remove a shelf, pull forward until the stop is reached, then lift at the front and pull out of the oven. Use reverse procedure to refit. If the shelves pull straight out then they are in back to front!

WARNING

If any part of the stove begins to glow it is being over fired. Stop use immediately and allow to cool. If this occurs it is recommended that the cooker is cleaned and inspected before further use and any warped baffles straightened.

EXTENDED WOODBURNING

This appliance has not been certified as a slow combustion stove. Loading a large amount of wood into the cooking stove all at once will reduce the temperature inside. If the temperature is too low, the gases given off from the wood will be too low to combust, resulting in a lot of smoke which will cover the inside of the cooking stove, including the glass, with soot.

In order to avoid adverse combustion conditions it is a good idea to increase the temperature of the cooking stove before loading more wood by further opening the air control. Load the wood and leave the air control open until the moisture is driven out of the wood and the cooking stove is up to an efficient operating temperature. The air control and the bolster lid can then be closed to hold the temperature of the cooking stove.

The cooking stove can be set up to burn overnight if desired.

CLEANING AND MAINTAINANCE

The successful operation of your cook stove is entirely dependent on the adequate performance (pull) of the chimney or flue to which it is connected. The following maintenance guidelines will be pointless unless the flue is also maintained and cleaned regularly. How often it needs cleaning will depend on the quality and moisture content of the wood you burn but an annual clean is recommended. A partially blocked or dirty flue can have disastrous implications for an otherwise perfectly installed cooker.

A healthy flue draught should read between 12 – 25 pascals. A flue draught reading below this value will result in poor smoky performance

Always carry out cleaning procedures when the cook stove is unlit and has been allowed to cool sufficiently to avoid burns. With time and experience you will be able to gauge the intervals between cleaning more accurately. It will vary depending on the quality of your firewood and performance of your flue. Take time to get to know your cooker and inspect it at regular intervals for the first 6 months.

As the cooking stove top is used for cooking, normal wear and tear will occur. Spills should be mopped up immediately with a damp cloth, but oven cleaners should not be used on the hob surface.

The oven and hotplate will rust if surface moisture is left on. Remember to always light the cooker to warm and dry these after cleaning. To season the oven or hotplate, we recommend a light vegetable oil spray is used. Remove any stubborn stains with the wire brush.

To clean the glass of any built up residue, special cleaning solutions can be used, or a ball of newspaper dampened and passed through the ash can be used. Do not use abrasive or chemically aggressive cleaning products on the glass as this can weaken or stain it.

If any of the chromed components become blue due to excess heat they can be restored using a chrome cleaner.

The exterior of the cooking stove is painted with high temperature resistant cooking stove paint and from time to time it may become necessary to renovate

the exterior by repainting. The surface must be prepared by rubbing down with a wire brush. The cooking stove paint will not key to the surface if there are fat deposits or food particles on the area to be resprayed. High temperature resistant cooking stove paints are available in aerosol form from your cooking stove dealer, or from www.esse.com/spareparts/. Do not use this paint until the cooking stove is completely cold and always follow the instructions on the container before starting to paint. The usual precautions should be taken, such as covering adjoining surfaces and protecting the hob lids.

The hob lids are made of chromed steel. The lids can be wiped clean with a damp cloth and proprietary chrome cleaners may be used.

When de-ashing the cooking stove only remove small amounts of ash leaving ideally 30mm depth of ash in the bottom for best performance.

To clean the flue way of the cook stove the hotplate must be removed. With the hotplate removed the flue brush can be used to brush around the ovens and beneath the top. Once the exterior of the ovens has been brushed the flue access plate behind the lower right door can be removed and any loose debris can be raked out using the flue rake. A vacuum can also be used for this process.

All panels should be replaced after cleaning.

Cleaning the Flue

It is recommended that the flue is cleaned at least every 12 months to maintain a suitable flue draught and prevent poor performance of the cooking stove. It is essential to maintain the integrity and cleanliness of the flue to ensure that your cooker continues to perform at its best. When your cooker was installed the main flue should have been equipped with an inspection hatch. These hatches are designed to allow periodic access to the flue for inspection & cleaning.

If the chimney was previously used for an open fire, ensure any obstructions or dampers are removed or locked open. The cooking stove operates at higher flue gas temperatures, deposits of soot and debris that were firmly adhered to the inside of the chimney, when it was used with an open fire, can loosen and cause a blockage. We recommend that in such a situation a second sweeping of the chimney should be carried out within one month of regular use of the cooking stove after installation.

CONDITIONS OF GUARANTEE

Your ESSE is guaranteed against defects arising from faulty manufacture for 2 years when supplied by an ESSE Specialist.

Upon registration of the warranty, ESSE will extend the guarantee period to 5 years from purchase. Your details must be registered with us by either returning the completed warranty card or by completing registration on-line at www.esse.com. The warranty must be registered within 1 month of installation to qualify for the 5 year warranty.

The appliance must be only used for normal domestic purposes and in accordance with our instructions, be correctly installed and serviced.

EXCLUSIONS

This guarantee does not cover:

- Installation
- Wear & tear
- Parts deemed to be replaceable in the normal usage of the cooker. These parts are listed herewith: all firebricks, woodburning box, oven accessories, hotplate and door seals, door glass.

This guarantee is personal to the original purchaser and not transferable.

Any stove or defective part replaced shall become the Company's property.

CUSTOMER CARE

In the event you should require spare parts, please order through your ESSE dealer or by contacting Esse via telephone (01282 813235) or our website, www.esse.com.

Should you have cause for dissatisfaction with your cooker, you should contact your ESSE dealer, who will, in most instances, be able to offer you immediate assistance. You will be required to give the following details.

- Your name, address and postcode.
- Your telephone/contact details.
- Clear and concise details of the fault.
- Model and serial number of the cooker (found on panel at rear).
- Purchase date (please note that a valid purchase receipt or guarantee documentation is required for in-guarantee service calls).

We will then check that we have an accurately completed warranty card, if not then any work carried out may be charged.

We will assess the nature of the complaint and either send replacement parts for your dealer to fit, send an engineer to inspect & report, or send an engineer to repair. If the fault is not actually due to faulty workmanship but some other cause such as misuse or failure to install correctly, a charge will be made to cover the cost of the visit and any new parts required, even during the warranty period. Home visits are made between 08.30-1700 hrs Monday to Friday, and are arranged for either a morning or afternoon appointment.

SAFETY NOTES

- Properly installed, operated and maintained, this appliance will not emit fumes into the dwelling. However, occasional fumes from de-ashing and re-fuelling may occur.
- Persistent fume emission is potentially dangerous and must not be tolerated. If fume emission does persist, open doors and windows to

ventilate the room. Let the fire burn out or eject and safely dispose of fuel from the appliance. Once the fire is cold, check the flue and chimney for blockages and clean if required. Do not attempt to relight the fire until the cause of the fume emission has been identified and corrected.

- Seek expert advice if necessary.
- An adequate air supply for combustion and ventilation is essential. Air openings provided for this purpose must not be restricted.
- Should it be likely that children, aged, or infirm people approach the appliance whilst the fire door is open, then a fireguard manufactured in accordance with BS 6539 should be used. Also warn children not to sit or stand on the appliance or use it as a 'step-stool' for access to cupboards or shelves etc. above the appliance.
- Avoid the use of aerosol sprays in the vicinity of the cooking stove when it is in operation and do not heat any unopened airtight containers.
- Ensure that precautions are taken when deep fat frying, never leave the appliance unattended and ensure you have fire safety equipment available, such as a fire blanket, in case of emergency.
- When operating the cooking stove use the tools provided and follow these instructions carefully.
- In the UK, the installer has a responsibility under the Health and Safety at Work Act 1974 to provide for the safety of persons carrying out the installation.
- Attention is drawn to the fact that fire cement is caustic and hands must be washed thoroughly after use.
- The appliance is heavy and care must be taken during handling.
- Although the appliance does not contain asbestos products, it is possible that asbestos may be disturbed in existing installations and every precaution must be taken.
- These instructions give a guide for the installation of the appliance but in no way absolve the installer from responsibilities to conform to British Standards, in particular BS8303 and BS6461, relating to the installation of solid fuel appliances. All local regulations including those referring to national and European standards need to be complied with, when installing this appliance.
- Outside of the UK, the installer must comply with all local, national & European standards that apply.



Ironheart

INSTALLATION INSTRUCTIONS

GENERAL SAFETY INFORMATION

In the UK, the installer has a responsibility under the Health and Safety at Work Act 1974 to provide for the safety of persons carrying out the installation. Attention is drawn to the fact that fire cement is caustic and hands must be washed thoroughly after use. The appliance is heavy and care must be taken during handling. Although the appliance does not contain asbestos products, it is possible that asbestos may be disturbed in existing installations and every precaution must be taken.

These instructions give a guide for the installation of the appliance but in no way absolve the installer from responsibilities to conform to British Standards, in particular BS8303 and BS6461, relating to the installation of solid fuel appliances. All local regulations including those referring to national and European standards need to be complied with, when installing this appliance.

Outside of the UK, the installer must comply with all local, national & European standards that apply.

It is also recommended that a smoke alarm and appropriate fire safety equipment such as a fire extinguisher and fire blanket are installed in the kitchen as a safety precaution and also a carbon monoxide detector.

An adequate air supply for combustion and ventilation is required. A purpose provided air vent maybe necessary. Air openings provided for this purpose must not be restricted. An external air kit is available.

DIMENSIONS AND CLEARANCES

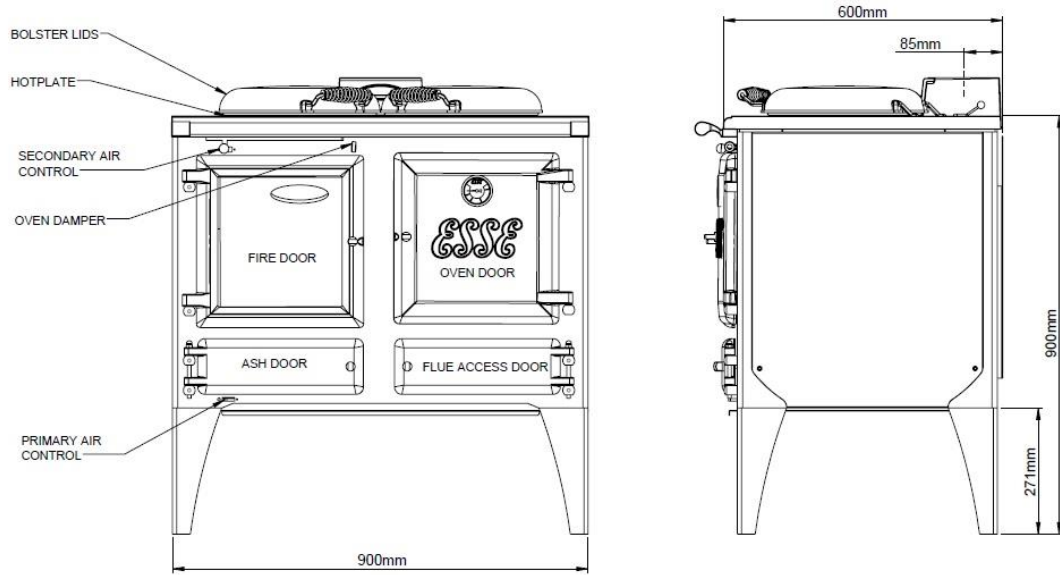

Figure 10 Ironheart Dimensions

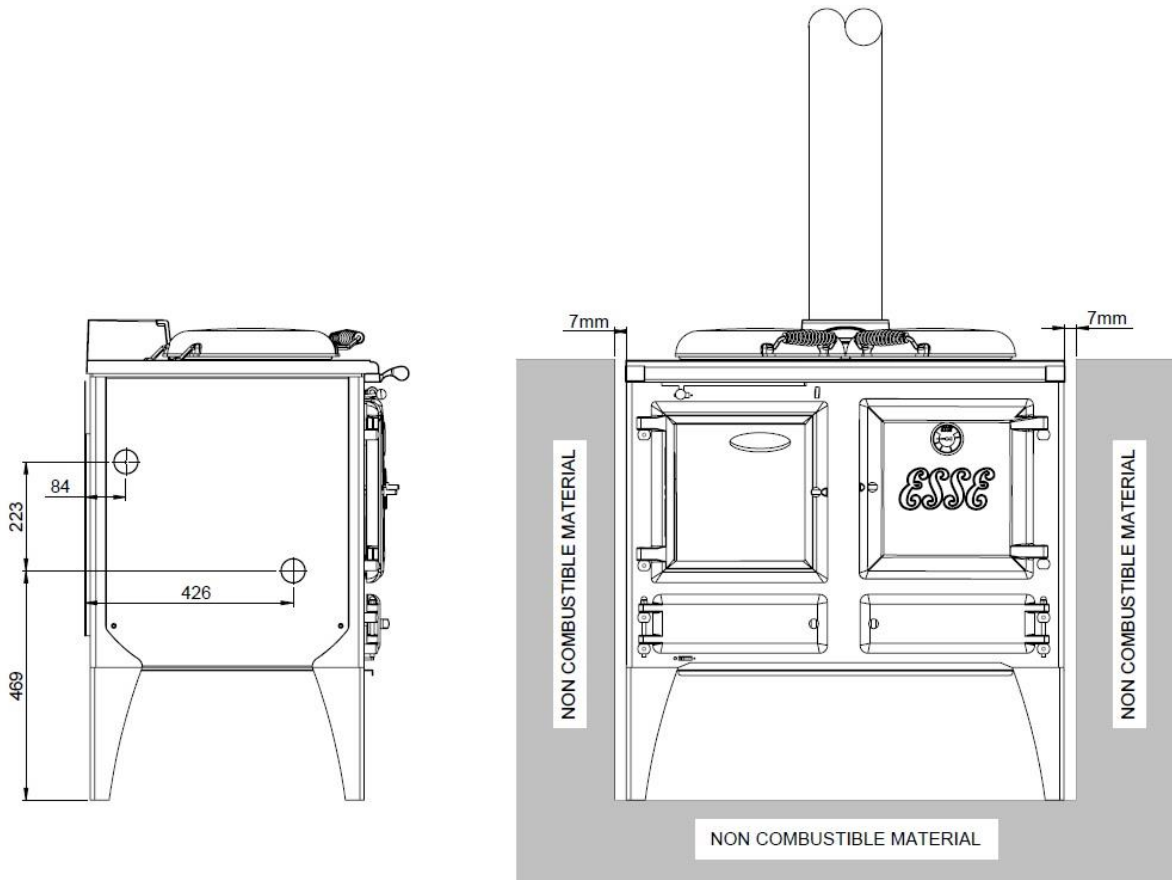

Figure 11 Boiler Tapping Locations & Minimum Clearances to None Combustibles

Clearances From Combustibles

	EW	EWB
Sides	300	200
Back	500	400

Any adjacent combustible material should be far enough away from the cooking stove so as not to rise 60°C above the room temperature when the cooking stove is in operation. If necessary, any adjoining walls should be protected from the effects of heat.

Due to the hand crafted nature of the products all dimensions are $\pm 2\text{mm}$

CHIMNEY AND FLUE INFORMATION

The successful operation of the cooking appliance relies on the adequate performance of the chimney to which it is connected. The following chimney guidelines must be followed:

- It should have an internal cross section of no less than 320cm² (200mm dia.) (If a flue liner is used, it should be 150mm (6'') diameter and be made of suitable material for burning wood). A Flue with a diameter of 150mm (6''), is required to connect to the cooker.
- Voids in the chimney should be avoided, as these will prevent a steady flue draught. The appliance flue pipe should pass beyond the narrowing of the chimney.
- Terminate at least 1m above roof level so that the chimney does not terminate in a pressure zone.
- If the appliance is installed as a freestanding appliance, it should not support any part of the chimney.
- Be free from cracks, severe bends, voids, and obstructions.
- Be connected to this one appliance only.
- New chimneys must be in accordance with local regulations.
- The chimney must be capped to prevent ingress of rain.
- A flue/chimney access point is required so that the state of the chimney can be checked and any fallen soot removed.

- External flues must be insulated to prevent heat loss.
- Do not fit an extractor fan in the same room as the appliance.
- Be a minimum 4.6m high from top of the cooker to the chimney pot.
- It is recommended that an inspection hatch is fitted to the chimney as this will make future cleaning easier.
- A single wall starter length with a single to twin wall adapter will be needed to use twin wall insulated flue. The stove will need to be moved away from the wall to accommodate use of twin wall flue.

NOTE

The chimney/flue to which this appliance is being connected must be swept and examined for soundness prior to installation. Remedial action should be taken if required, seeking expert advice if necessary. Where the chimney is believed to have served an open fire installation it is possible that a higher flue gas temperature from a closed appliance may loosen deposits that were firmly adhered, with the consequent risk of flue blockage. It is therefore recommended that the chimney be swept a second time within a month of regular use after installation.

Flue Draught

The chimney can be checked before the appliance is installed with a smoke match. If the chimney doesn't pull the smoke, it may suggest the chimney needs attention.

This test is only a guide as an apparently poor flue may improve once the appliance is installed, lit and the flue is warmed. Once the appliance is installed a flue draught reading should be taken as detailed below.

Two flue draught readings should be taken, one with the appliance at minimum burning rate and one at maximum burning rate. The flue draught can be measured behind the flue box door on the top of the cooker.

Minimum reading: The appliance should be lit and allowed to warm the flue thoroughly. Close the air controls, and ensure firebox door is fully closed. Allow the burning rate to become steady. The flue draught reading should now be taken; the minimum required is 12 Pascals [Pa] (0.05" w.g.).

Maximum reading: The air controls can now be opened to allow the appliance to burn at maximum rate. Take a flue draught reading.

Ideally, the flue draught readings should range between 12Pa, 0.12mm (0.05” w.g.) and 25Pa, 2.5mm (0.1” w.g.). Any readings significantly outside this range may indicate the need for remedial action. Low flue draught symptoms: difficult to light and smoke coming into the room. High flue draught symptoms: fuel burns away very quickly, overfiring which may damage the appliance & invalidate the warranty.

A flue stabiliser can be fitted to reduce the draught through the appliance if the draught may exceed 25Pa. The flue stabiliser should be fitted in the same room as the appliance and be the same size as the flue pipe. Consult building regulations regarding additional ventilation.

A fan flue booster can also be fitted if the flue draught is poor. This should be fitted according to the instructions supplied with the booster. An electrical supply will be needed.

Table 1 Flue Draught Trouble Shooting Guide

Low flue draught symptoms: difficult to light and smoke coming into room	
CAUSE	REMEDY
Cold chimney	Line the Chimney
Chimney too short	Extend the chimney
Down draught	Relocate/extend chimney terminal. Fit an anti-down draught cowl
Chimney diameter too large	Line the chimney
Chimney obstruction	Clear/sweep the chimney
Restricted air supply	Check for competing draughts (other chimneys, extractor hoods/fans). Fit an air vent if the room is sealed.
High flue draught symptoms: fire difficult to control, fuel will not last, stove too hot, stove damage, chimney fire	
CAUSE	REMEDY
External wind conditions combined with chimney terminal	Fit stabiliser cowl Fit flue draught stabiliser

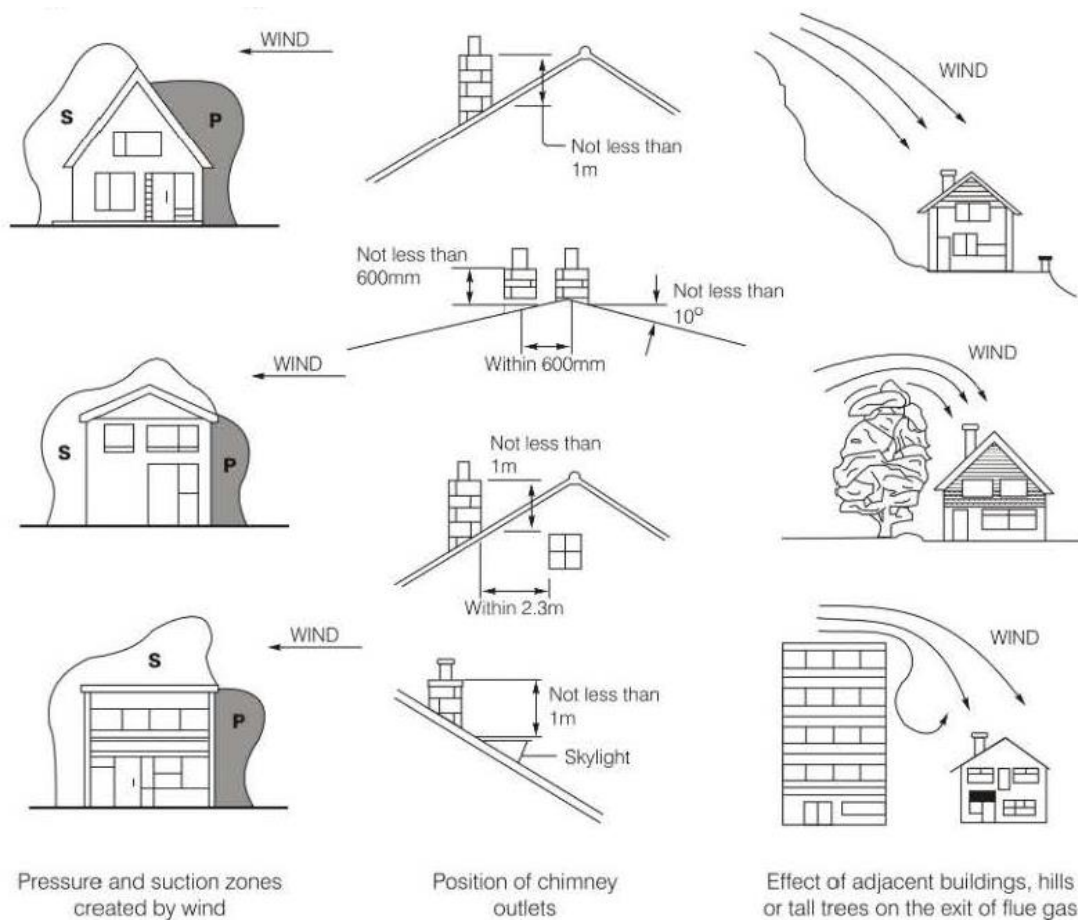

Figure 12 Chimney Location and Flue Performance

INSTALLING THE APPLIANCE

Flue Connection

The flue pipe used to connect the appliance to the chimney is 6" (150mm) in diameter. (The flue connection is on the top of the appliance, in the centre at the back.)

Important Installation Notes

- The installation must allow access for adequate chimney sweeping and flue cleaning.
- Avoid using bends greater than 45° to the vertical. All flue pipe sections should be as close to the vertical as possible.
- All joints in the flue system must be effectively sealed.

- All flue sockets must face upwards. On completing the installation of the appliance, the chimney, hearth and walls adjacent to the cooker must conform to local or national regulations currently in force. In the United Kingdom, the appropriate sections of the Building Regulations must be conformed to.
- Air inlet grilles should be positioned so that they are not liable to blockage.
- An air extraction device shall not be used in the same room as the appliance unless adequate additional ventilation is provided.
- A flue cleaning hatch should be fitted to provide access for cleaning the flue and chimney.
- Check the appliance for soundness of seals between main components and that all supplied parts and fittings are correctly fitted.
- Upon successful installation, using a 5mm Allen key, remove the two M6 transit socket screws in the hotplate. Using a 4mm Allen key, insert the two M8x8 grub screws supplied with the cooker into the holes in the hotplate and adjust until the head of the grub screw is level with the surface of the hotplate. These grub screws can be removed and re-fitted during and after cleaning of the appliance.
- Ensure the appliance is left operational, the domestic hot water system is connected properly if applicable and hand over the operating instructions and operating tools supplied.
- Before leaving the installation demonstrate the operation of the appliance to the user. Explain all controls and flue way access for cleaning.

HOT WATER SYSTEM (EWB MODELS ONLY)

There are two connections, both 1" BSP Female on the left hand side. Follow general notes below:

The EWB or DE-LUXE boiler is plain mild steel and capable of running a radiator in addition to domestic hot water.

General Notes on Water System:-

- The cooking stove will produce hot water at differing rates depending on how it is operated. Heating control is manual, no thermostat is fitted.
- The system must be designed to cope with loads between the maximum and minimum output. The gravity load must absorb 2.6kW for periods when the oven is being used for cooking, e.g. domestic hot water plus gravity operated radiator.
- An indirect storage cylinder is essential for domestic hot water supply, irrespective of whether the water supply is hard or soft. Minimum capacity 30 gallons. Cylinder should be as close to cooker as possible.
- The primary domestic supply must be gravity operated
- The layout must follow established heating engineering practice. To avoid trapping air in the boiler a 1" BSP connection must be used on the flow and return pipes, and any reduction in pipe size thereafter being made on a vertical rising pipe.
- The cooker must be level when fitted and the flow pipe must rise from the boiler. A drain cock must be fitted on the lowest point of the return pipe and a vent to atmosphere at the highest point of each circuit.
- The cylinder and pipe work should be lagged to avoid heat loss.
- The static head must not exceed 60 feet of water.
- The total water capacity of the boiler is 4 litres.
- A heat leak radiator should be fitted to absorb any excess heat that may be produced.
- The system must be properly vented.

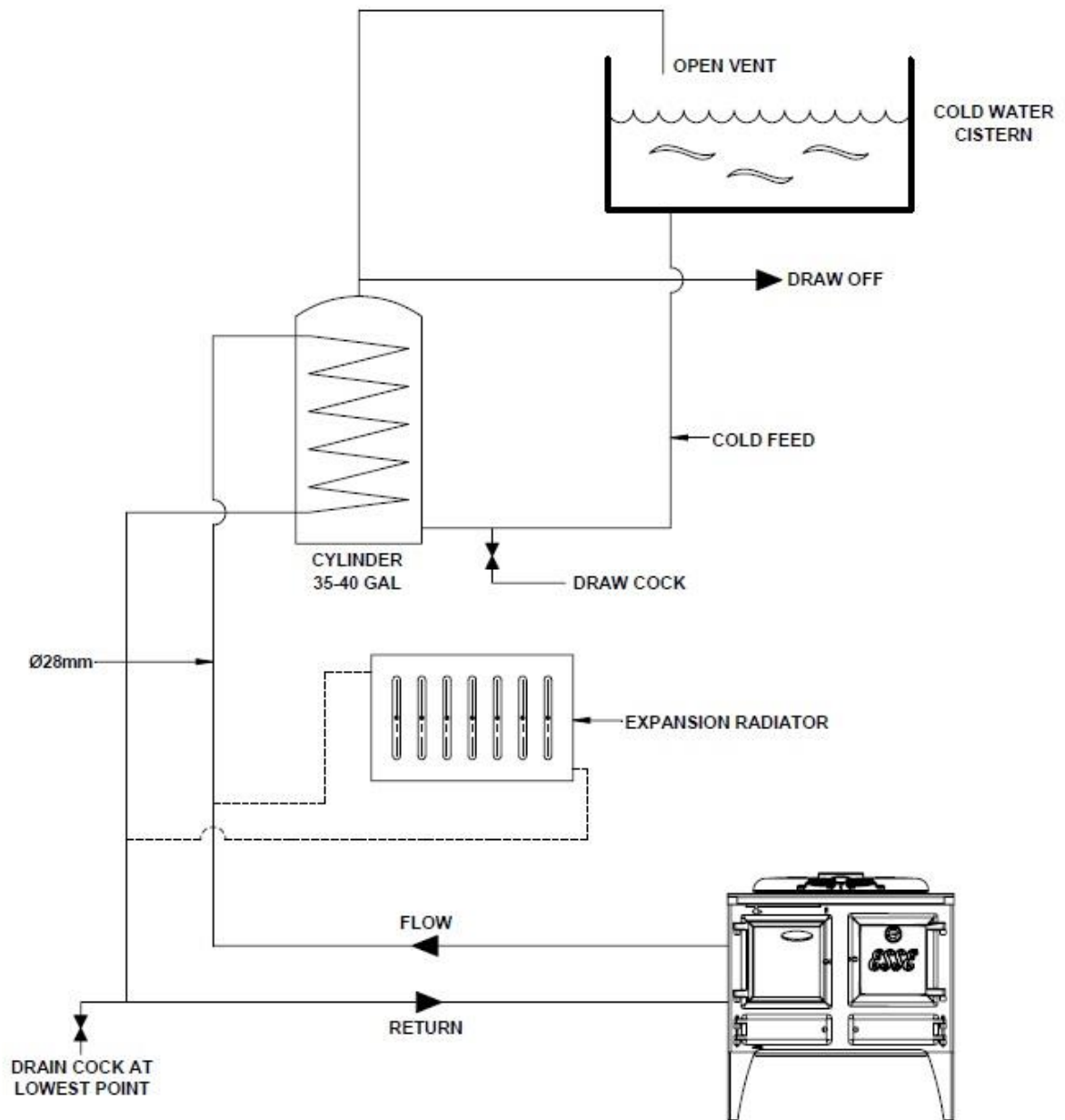

Figure 13 Typical DHW Gravity System

COMMISSIONING THE APPLIANCE

- Measure and record flue draught
- Check ventilation
- If applicable check plumbing circuit
- Check no extractor fan, other appliance or other flue interferes
- Complete commissioning card and return to ESSE to validate warranty

REPLACEMENT PARTS

1. Upper Door Handles	EW-062	23. Bolster Lid Assembly	WCKLIDSET-002
2. Lower Door Handles	ES-006	24. Hinge Assembly	CENT-022
3. Magnet Catch	EW-042	25. Flue Damper	EW-048
4. Ash Door	EW-005	26. Cast Iron Flue Box	EW-036
5. Flue Access Door	EW-009	27. 5" to 6" Flue Adaptor (Optional Extra)	VIA50CG
6. Flue Access Plate	EW-013	28. Bolster Lid Handle	2023-814X BO CH
7. Ash Pan	EW-014	29. Towel Rail Bracket	LHTRB or RHTRB
8. Cast Iron Grates	WC BG1	30. Towel Rail	CENT-090 BO
9. Wire Shelf	EW-020	31. Flue Heat Shield	EW-023
10. Oven Shelf Support	LHTOSR or RHTOSR	32. Upper Air Slider	EW-022
11. Lower Air Slider	EW-017	33. Fire Door Hinge	ECS00572
12. Legs	EW-033	34. L/H Side Panel	EW-026R
13. Bottom Heat Shield	EW-032	35. Baffle Plate	FC-012
14. Lower Door Hinge	EW-064	36. Fire Brick Set	EW-100
15. Oven Door Hinge	EW-064A	37. Fuel Guard	FC FG
16. Stove Body	EW-031A	38. Oven Door Liner	EW-010
17. R/H Side Panel	EW-026R	39. Cast Oven Door	EW-040
18. Rear Heat Shield	EW-034	40. Glass Window	FC-045
19. Flue Restrictor Guide	EW-035	41. Thermometer Dial	x812/C BO CH
20. Flue Restrictor	FC-023Q	42. Cast Fire Door	EW-004
21. Cast Iron Top	EW-029 FA	43. Fire Guard	EW-003F
22. Hotplate	CENT-073 F		

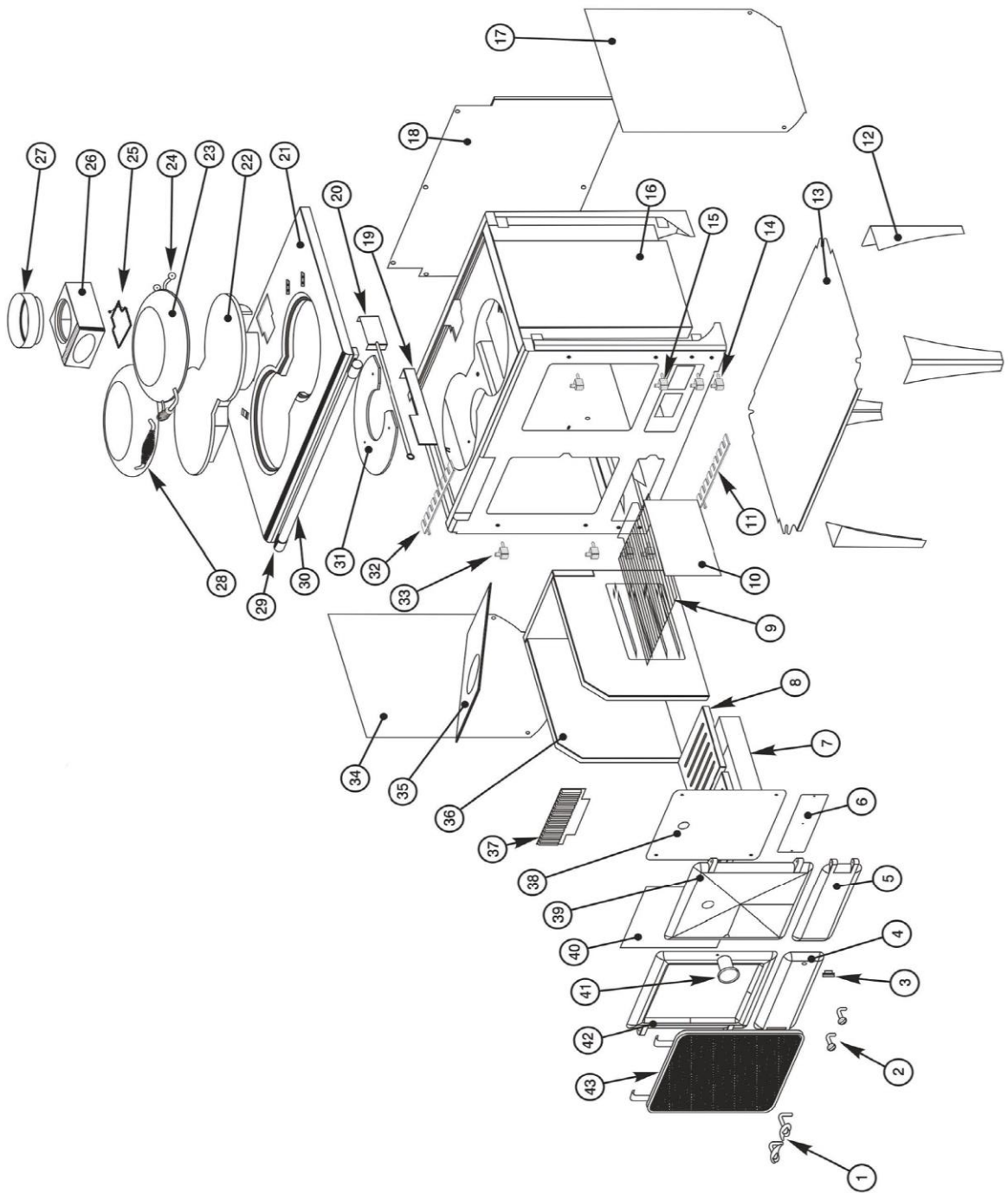

COMMISSIONING CHECKLIST

To assist with any potential guarantee claim please complete the following information:-

To be completed by the installer.

Dealer the appliance was purchased from:

Name:

Address:

Telephone No:

ESSENTIAL information:

Date Installed

Model Description:

Serial No:

Installation Engineer:

Company Name:

Address:

Telephone No:

Commissioning Checks – to be completed and signed:

Has the use of the appliance,
operation and controls been
explained?

Yes

No

Instruction book handed to the
customer?

Yes

No

Signature:.....

Print Name:.....

TECHNICAL INFORMATION

	EW	EWB
Nominal Heat Output (kW)	9.7	10.5
Boiler Heat Output (kW)	--	2.6
Combustion Air Requirements (m ³ /h)	40	55
Air Vent Size (cm ²)	30	50
Weight of Appliance (kg)	370	375
Minimum Chimney Draught (Pa)	12	12
Mean Flue Gas Temperature (°C)	250	255
Flue Gas Mass Flow (g/s)	18.5	13.7

ESSE

ESSE Engineering Limited, Ouzledale Foundry, Long Ing, Barnoldswick, Lancashire

BB18 6BJ

Tel. 01282 813 235, **Fax:** 01282 816 876

Website and On-line Store <http://www.esse.com>

Topstak

Esse Woodburning and Multifuel stoves
supplied by Topstak

www.topstak.co.uk/stoves/stoves-by-brand/esse-stoves/

We have an unrivalled range of chimneys,
stoves, bespoke kitchens, flooring and
handcrafted furniture manufactured to the
highest quality.

Cowbridge Showroom

Unit 42, Vale Business Park

Llandow

Cowbridge

CF71 7PF

01446 771567

info@topstak.co.uk

Monmouth Showroom

Mayhill Industrial Estate

Staunton Road

Monmouth

NP25 3LX

01600 711710

info@topstak.co.uk